

AT MICROFICHE
REFERENCE
LIBRARY

A project of Volunteers in Asia

Mini Technology II

by A. Bachmann and B.R. Saubolle

Published by:

UNICEF
P.O. Box 1187
Kathmandu
NEPAL

Available from:

same as above

Reproduced by permission.

Reproduction of this microfiche document in any form is subject to the same restrictions as those of the original document.

**MINI
TECHNOLOGY
II**

**A. BACHMANN
B.R. SAUBOLLE**

**MINI
TECHNOLOGY
II**

**A. BACHMANN
B.R. SAUBOLLE**

**SAHAYOGI PRESS
KATHMANDU**

Published by:
Sahayogi Press
Tripureshwar
Kathmandu
Phone: 11489

First Edition: April 1983

Copyright is reserved by the authors, but permission is hereby granted for the reproduction of any part, text, drawing or photograph, for non-profit-publication; however, the whole booklet, or any major portion should not be reproduced without permission. Anyone making use of the material presented herein is requested to acknowledge the source and submit the authors a copy of the excerpt.

Printed in Nepal
at Sahayogi Press

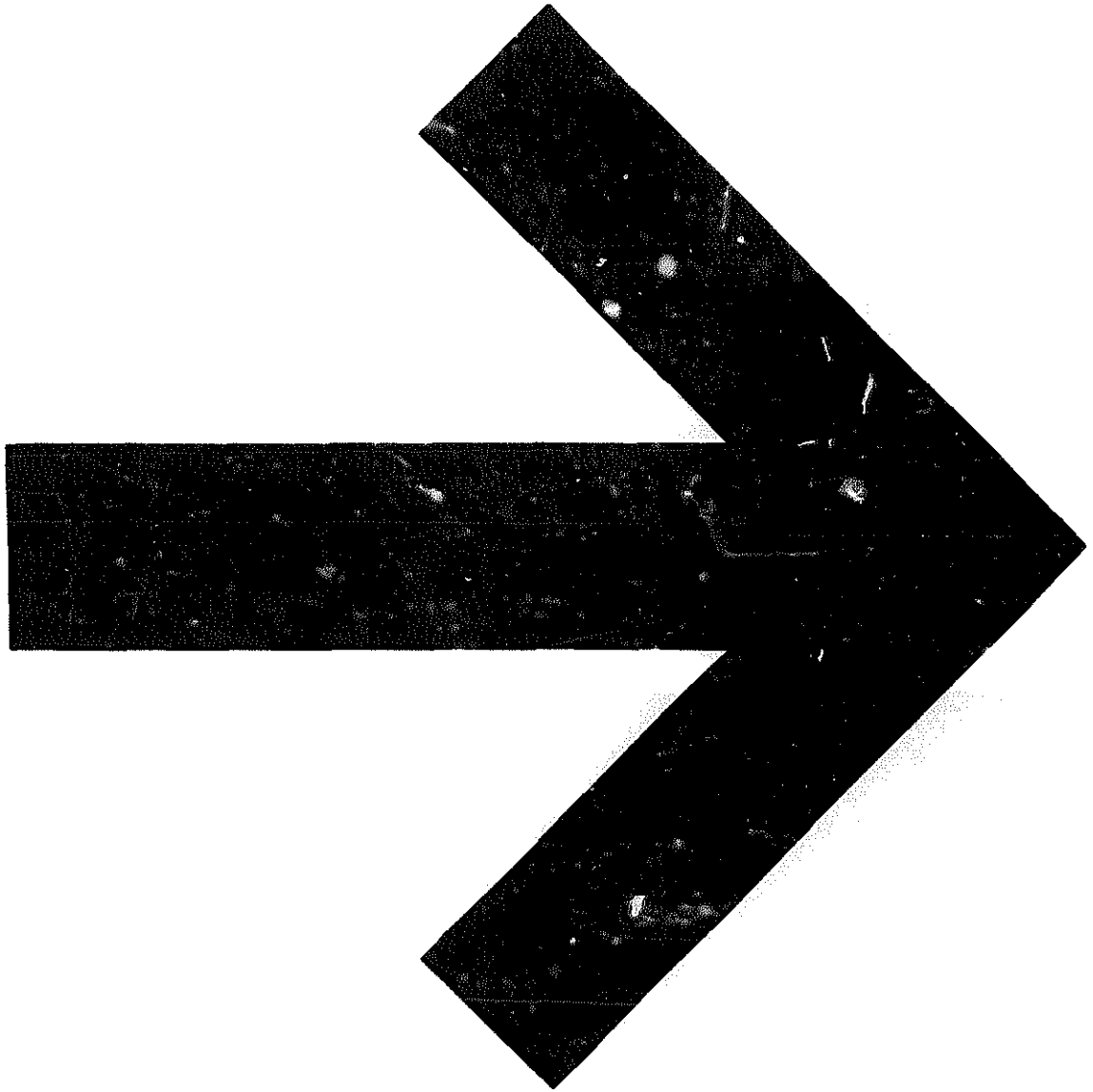

CONTENTS

Foreword	7
A Mini Biogas Digester	8
Water Powered Pestle Hammer	10
Tubelights on 12-Volts	13
The Black Bag Solar Heater	15
A Multi-Purpose Power-Unit	16
Barker's Turbine	19
Handcarts	21
A Straw Chopper	23
A Village Theodolite	24
The Korean Winnower	25
New Hand-Held Corn-Sheller	26
The Dhikki	26
The Carpenter's Horse	29
A Small Brick Oven	31
Another New Nepali Chulo	32
Smokeless Kitchens	35
The Hwogwo	37
Cooking Stoves with Hot Water Production	39
Fighting the Bugs	43
Sheet Metal Pipes	44
Hay Box Cooking	45

Mushroom Cultivation	46
Flying Foxes	48
Rabbit Rearing for Villagers	48
Ginger Ale	52
Compost Making Drum	53
Preserving Flowers	53
A Water Scoop	57
An Odourless Pit Privy	58
Uses for Burnt-Out Bulbs	60
Snails	61
Recycling	61
Rat Disposal	63
The Nepali Queen Excluder	64
Fence Post Driver	66
Acknowledgement	68

FOREWORD

In the first volume of 1978 Rev. B.R. Saubolle mentioned the wheel barrow as a practical example of common interest in self-help achievement of many people.

Collecting more information over the past years, again we realized that it is by no means an easy task to provide "solutions" to "simple problems" - and this is also very true for the wheel barrow. Each of the many different wheel barrows provide their own advantages and disadvantages. Still, we think it is worthwhile to work on the further exchange of information in the field of locally-feasible technologies in these parts of the world.

The great change on this subject for us here in Nepal is the death of Father Saubolle. He died at the age of 78 years on 24 May 1982 in his beloved land of Nepal. He was the initiator of so many ideas, many of which sounded unrealistic at the time when he first introduced them. Yet these ideas have proven themselves as worthy, and many people continue to gain from Father Saubolle's tireless efforts to improve the lives of the poor.



Late Father Saubolle with his demonstration biogas plant; the first digester of Nepal.

A MINI BIOGAS DIGESTER

"Seeing is believing", goes the saying, and a small demonstration plant may well be the best means to induce the sceptics to adopt the use of biogas.

In Nepal, for example, such a plant, made from a 200 ltr oil drum, was the first biogas plant. It was made over twenty years ago, nowadays there are over 1200 family size plants installed all over the warmer parts of Nepal. The initial design has been steadily improved and has found application in other countries as a helpful device for the stimulation of new activities.

A 200-litre digester, of course, will not produce enough gas to do any steady, useful work like cooking a meal. It may light a stove for some 15 minutes once a day, and that is all, but a demonstration, just to show that the gas does burn, does not take more than one minute.

Such a digester would require a daily slurry (1:1 mixture of dung and water) input of at least six litres. If a little more gas is wanted, the daily input could be increased to ten litres. With this volume, however, full gas potential of the dung would not be realised; the effluent will continue fermenting slowly after being discharged. This does not matter, since our purpose is not to get all the gas possible, but to have sufficient for a proper demonstration.

Inside the drum there are four strips welded cross-wise; they break up the scum which may form on the slurry surface. The breaking up can be increased by rotating the drum. Where the scum is broken the gas can easily travel through the pipe to the burners.

To start such a digester, fill it with equal volumes of fresh dung and water and mix well. It takes about a month for gas formation to start. Rapid formation can be achieved the first time if a good proportion of the water is septic tank effluent, which is rich in the required bacteria.

Once the drum is filled place the drum (=gasometer) in position with the gas outlet open, so that the drum can sink completely. When the drum rises for the first time it contains a mixture of gas and air, which may be explosive. Let this first drumful escape into the atmosphere. Let the drum rise again, this second filling is a safe gas.

BIO-GAS DEMONSTRATION PLANT
 USING AN OLD OIL DRUM

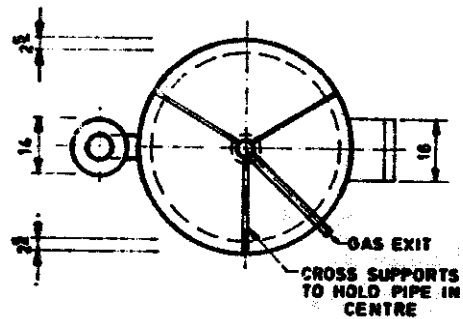
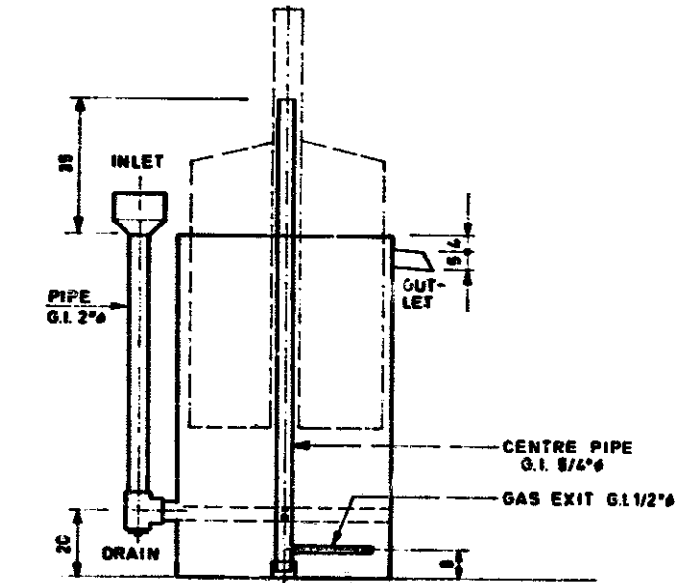

GAS DRUM

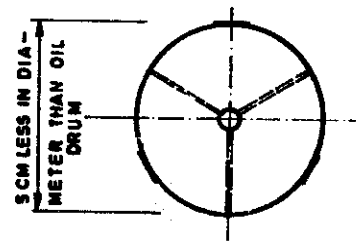
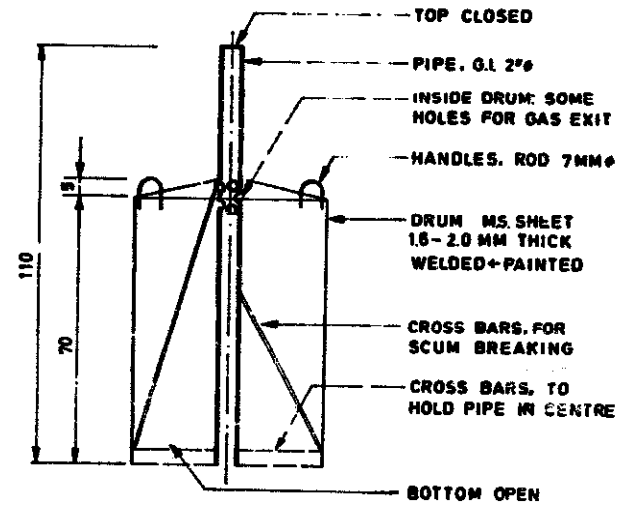

MEASUREMENTS IN CM / 12.75 0.50

Note that biogas plants work only in warmer climatic conditions.

When your first biogas is burnt and you are convinced yourself, simply carry it to the next place for demonstration purposes and build a family size for yourself.

For more information consult the author's booklet "Fuel Gas from Cowdung", Sahayogi Press, Tripureswar, Kathmandu.

WATER POWERED PESTLE HAMMER

The beating of agricultural produce is a very common process in many rural communities. This is mostly done by hand, mostly by women or children. It is not only rice and maize which can be processed this way, but many other things as well.

For this purpose, a water-powered pestle-hammer has been used for centuries in Asia, namely Korea and China, and also in North America. In remote areas of Asia it is still a very useful device, and it can be copied quite easily.

The efficiency is much more in the quantity to be beaten, the frequency of one stroke may be once in five to seven seconds, and efficiency is afterwards where large quantities are beaten with each stroke. It is also very suitable for sites with very low water head: 1.2 m will suffice, and many works -such as rice beating or dehulling- can go over hours without any supervision, day and night!

With this simple machine one can beat paper pulp, break stones to gravel, make a water stroke pump. air bellow for blacksmith, or whatever.

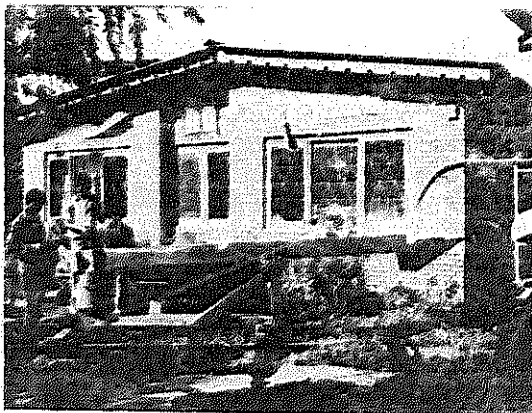

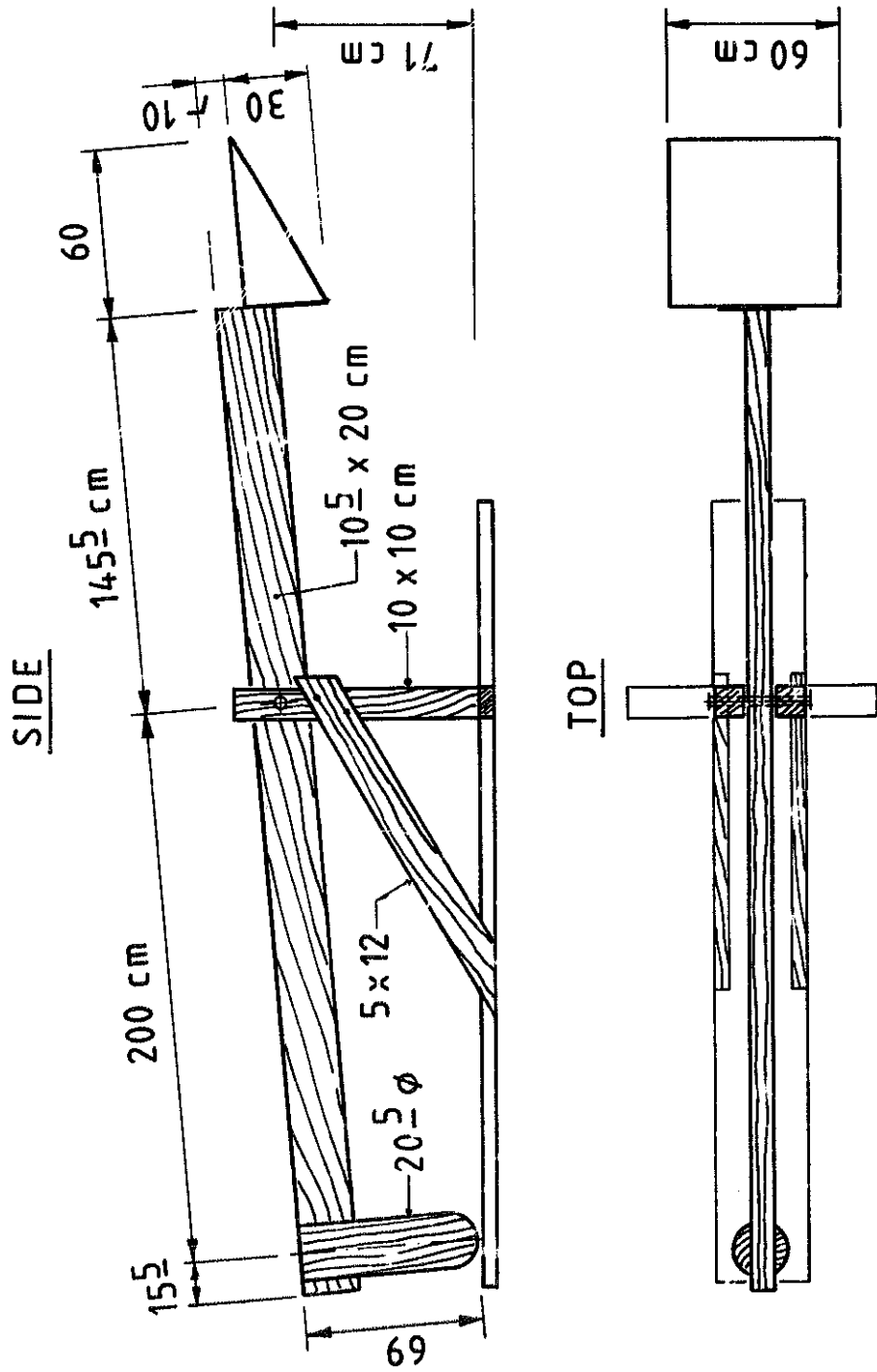

TUBELIGHTS ON 12 VOLTS

In some parts of the world the electric supply is unbelievable erratic. A dozen power failures a day is not at all uncommon, quite apart from deliberate "load shedding" for several hours at a stretch. People are taking more and more to storing current in 12-V batteries and using it at night to light standard fluorescent tube lamps. This emergency lighting is used in some country hospitals for the operation theatre, and in schools for the study halls and dining rooms. Some people here in Kathmandu light their homes at night, from 18:00 h to 22:00h with fifteen tubelights powered by a truck battery.

We give below a wiring diagram for adapting a standard 40-watt 220-volt tubelight to a 12-volt power supply. With such adapters at least three tubelights can burn for several hours at a stretch off a 9-plate 12-v Jeep battery.

The heart of the adapter is the inverter-transformer. In making this a 0.4 to 0.5 square inch iron laminated core seems sufficient. The low voltage coils (of SWG 20 or 19 and SWG 27 or 28) are wound side by side (bifilar winding), both having the same number of turns (45 is enough). The zero end (0) of the SWG 20 coil is connected to the 45 end of the SWG 27 coil.

- The high voltage side of the transformer can have between 600 and 1000 turns.
- Instead of the 1 mfd condenser 0.4 to 0.8 mfd may be tried.
- The transistor should have a good heat sink; it should not be made to carry more than 3.5 amps; a 5-amp fuse in the collector or emitter side of the transistor will prevent the transformer from burning out in the transformer fuses and short-circuits. The 100-ohm resistor can be varied to give the best light (for use with a 6-v battery it will have to be reduced to 50-70 ohms).
- The output of the adapter is high frequency; thus no starter and no choke are needed. Connections may be made to one or both pins at the ends of the tube (20-w tubes may be better for 6-v batteries).
- to reduce the high whining noise the transformer may be varnished or embedded in epoxy (e.g. Araldite).

- Each tubelight must have its own adapter.
- The emergency lights can be switched on automatically when the mains fail by the use of a rely. Its coil is energized by a separate rectifier attached to the low voltage side of the battery-charging transformer.

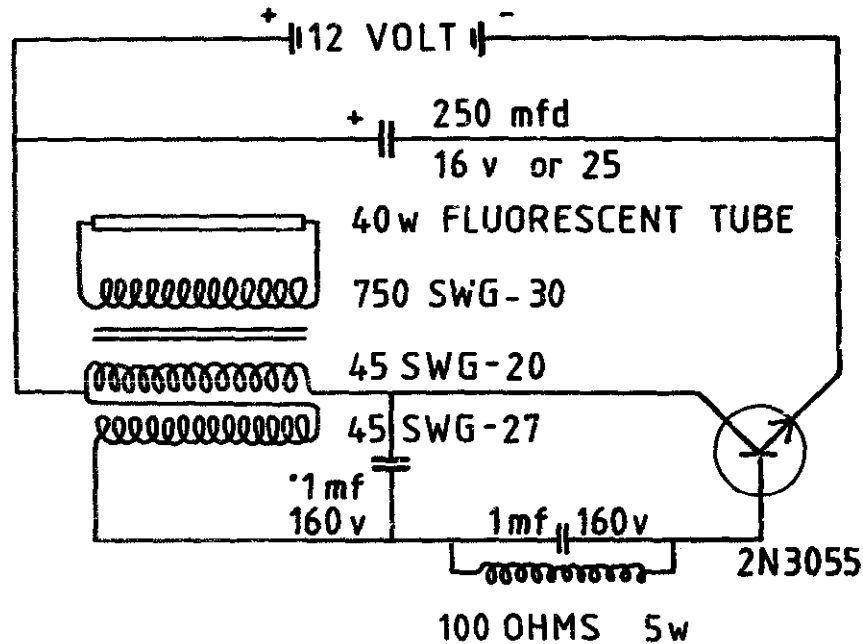

There's a story behind this adapter diagram. It comes from the physics professor of a Jesuit high school in India who made several of them for the school and the faculty building. One day a student of his asked for a copy. And in next to no time the boy's father went into business manufacturing and marketing adapters.

Nowadays solar cells are becoming popular for remote areas and there of course the same tubelights can be installed. Some people may also be satisfied by using normal bulbs, 12-v, 40-w or 60-w, these are cheaper and suitable where charging current is from the mains.

THE BLACK BAG SOLAR HEATER

In many countries round the world solar energy enthusiasts have hit upon the same idea. Call it "The Shallow Plastic Tank", "The Solar Pillow", "The Plastic Bag", or what you will; it is essential the same in every case. If a plastic bag is filled with water and placed in full sun, it will give you hot water in two or three hours. If such a bag is not readily available, we tell you here how one can easily made. All you need is black plastic sheeting, a 10 cm length of 1" diameter plastic pipe, a small strip of aluminium foil, and a hot iron.

The bag can be of any size you choose. One meter square is a convenient size; it will hold 20 liters. Cut two pieces of sheeting exactly the same size and place one of the other. Fold a piece of aluminium foil over the edges of the two sheets together to a width say 3 cm. The foil does not have to be a whole meter long; you can do a foot at a time. Pass the hot iron over the foil. The heat will bond the two sheets together. Without the foil the iron may burn a hole in the plastic and spoil the edges. In one of the corners bond in the bit of pipe to provide a mouth for filling and emptying the bag.

Twenty liters of water will fill the bag to a depth of 2 cm; 30 ltr to 3 cm. More than this is not recommended as it takes longer to heat up. The top sheet lies on the water, to which it communicates all the sun's heat that falls upon it (1 kW/sq.m), and it also prevents evaporation which would cool the water. In summer in full sun the water gets too hot to handle; in winter it becomes only nicely warm. To increase heat, cover the bag with a sheet of clear plastic about 3 cm away from the bag with the edges weighted down. This produces the hot-house effect and appreciably rises the temperature, while protecting the bag from any cooling breeze.

Another yet very simple solar heater is a 6-meter length of black HDPE plastic pipe laid flat on the roof in full sun. Cold water enters at one end and leaves the other. The pipe holds a trifle under 50 ltr of water, which gets very hot. It gets hotter still, and remains hot longer, if protected by a covering of clear plastic an inch away from the pipe. An insulation layer under the pipe coil further improves the efficiency.

A MULTI - PURPOSE POWER UNIT
with horizontal water turbine

From the Kingdom of Nepal in the Himalayas comes a jewel of a power plant. It is an updating of the ancient traditional water mill of the country used for grinding grain. The MPPU is constructed of metal and comprises three detachable segments easy to carry to distant places in the hills.

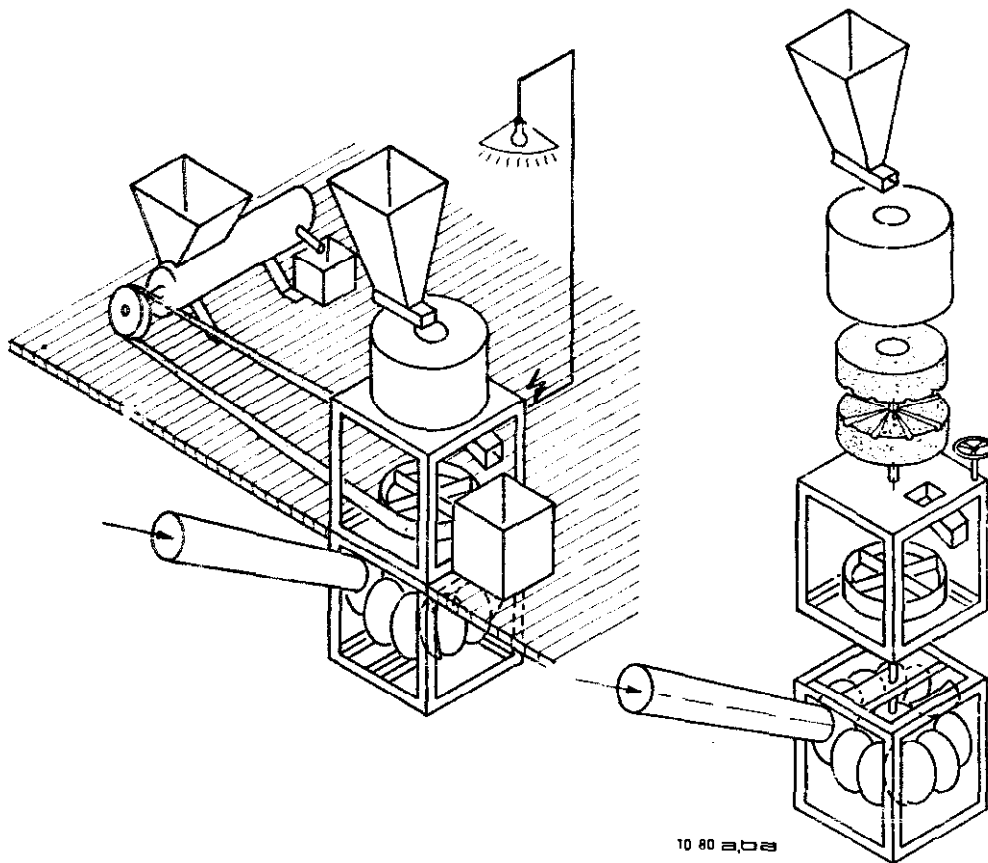

The lowest section holds the power drive, a scientifically made horizontal water wheel with cubbed blades. Where hydro power is not available the water wheel can be replaced by any other external power source, e.g. an electric motor or an internal combustion engine.

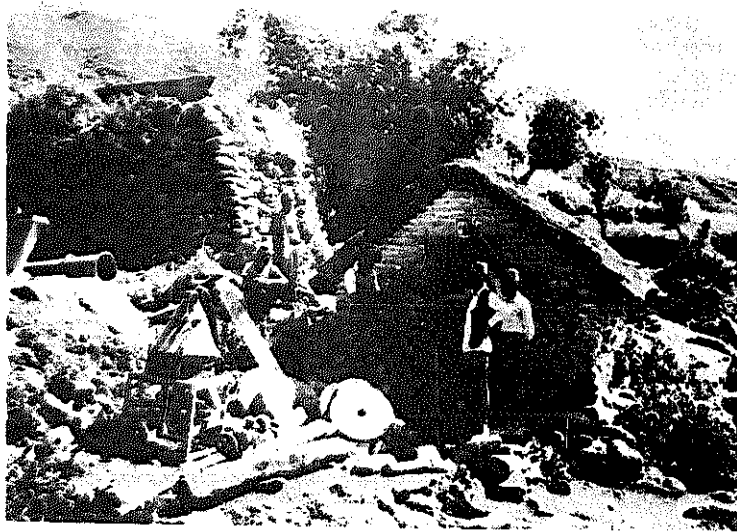

A Multi-Purpose Power-Unit dismantled in pieces, ready for installation.



The inside of a mill house: the MPPU runs several machines at a time.

The central section holds the power transfer mechanism attached to the vertical shaft of the water wheel. It may be a gear working a horizontal shaft with a power take-off pulley at either hand; though preferably, a pulley on the vertical shaft is made to turn an external horizontal shaft from which power is taken for a great variety of small machines: oil press, huller, trip hammer, electric generator, water pump, and so forth.

The topmost section has mill stones for grinding wheat, rice or maize. An odd feature of the MPPU is that the upper stone is fixed while the lower stone turns. Both stones are enclosed in a metal dust cover to keep the flour clean and to prevent it from being blown all around the room. Under the turning lower stone is a small brush that sweeps up the flour as it is thrown out, and neatly deposits it in a sack or basket. If the MPPU is not required to grind grain, the mill stones could be replaced by another pulley.

Obviously the power obtained depends on the head and volume of the water. One mill with a drop of 3 m head runs a 1.5 kW alternator while grinding grain at the same time. Another mill with 4 m head produces 4 h.p.

Besides doing two or three jobs at one time, the MPPU grinds grain much quicker than the old mills. Result: the customers can return home sooner, and the miller can earn more money faster. The increase in both speed and power is attributable to the improved blade design of the water wheel and to the use of proper bearings.

More information on the MPPU can be obtained from the booklet "Multi-Purpose Power-Unit, with horizontal water turbine", published by Sahayogi Press, Tripureswar, Kathmandu, Nepal.

BARKER'S TURBINE

Many have observed this principle at work in the garden sprinkler fixed to a hose pipe. The invention of this turbine dates back several centuries but the idea was forgotten for a long time.

Recently a Barker's Turbine was made in Nepal and found to be a good additional, low-cost water turbine. It functions quite simply: the vertical pipe (penstock) is at the same time also the moving part. Water flows in at the top and drains out at the bottom through the attached arms. The rotary motion of the central hollow shaft is obtained by the reaction of the water escaping at the end of its arms (and the water hitting against a wall) - the rotation being in the opposite direction to that of the escaping water.

A very useful aspect of this turbine is the ease with which the water flow may be regulated: simply close one, two or even three of the arms.

Data of the Nepal-version are as follows:

- Height of pipe: 5 mtr.
- Water Flow: 110 ltr/sec
- r.p.m. 100 - 150 (+- 10%)
- power expected: 5 kW
- diameter of hollow shaft: ca. 30 cm
- diameter of arms: 3" \emptyset G.I. pipes
- diameter of nozzles (4 pcs): 1 1/2" \emptyset (Reducers 3"-1 1/2")

A strong bearing on the bottom of the turbine is essential, as the whole weight of the turbine, including the water inside, will rest on it. It is also essential that the turbine be erected vertically. The power produced can easily be taken from the top from a pulley, fixed near the bearing.

BARKER'S TURBINE

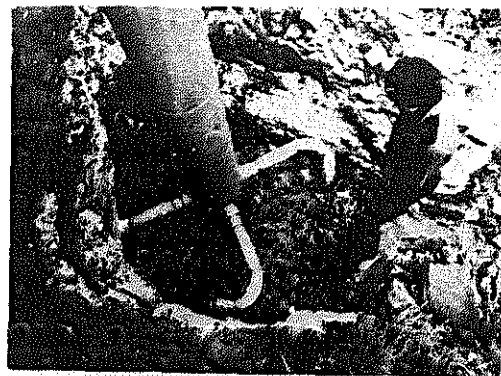
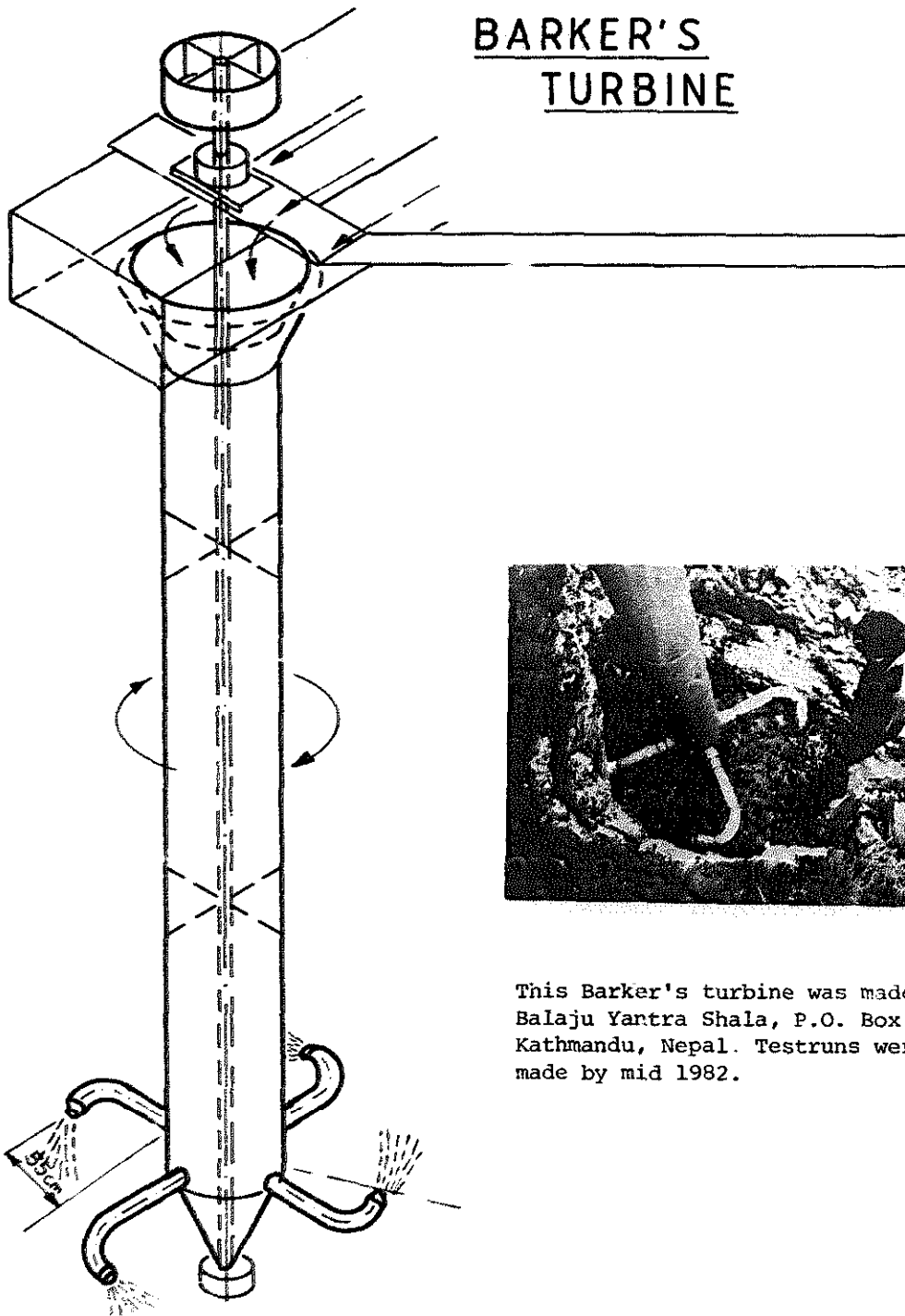

This Barker's turbine was made by Balaju Yantra Shala, P.O. Box 209 Kathmandu, Nepal. Testruns were made by mid 1982.

HANDCARTS

In the first edition of 'Mini Technology' the wheel barrow was mentioned only in the text of the preface. We thought it would be appropriate to present best wheel barrow. We have collected information materials and found many variations. All of them have certain advantages and disadvantages. The choice really depends on what material is to be transported.



TIPPING OVER All common wheelbarrows tip over so easily.



UNNATURAL STRAIN ...All wheelbarrows strain your back and heart!



SMALL OBSTACLES ...Tiny wheels won't even roll over little obstacles!



SUDDEN SHIFTING Poor design flops forward as load suddenly shifts forward.

One of the appealing designs for many people may be this type of handcart. This handcart has been developed and was tested in the USA, by David Tresemer.

The construction can be made from different materials and in smaller workshops. It has many applications, such as wood transportation, goat harness, hay cart, &c. We have not yet tried it out ourselves, but believe this type will be a useful instrument to many.



Ask for specific information: Handcart Handbook, by David Tresemer, c/o Hand and Foot, Ltd., P.O. Box 611, Brattleboro, Vermont, USA

A STRAW CHOPPER

Farmers constantly need a chopper for chopping up straw, grass, &c., for cattle fodder, which is mixed with grain and water and served as a mash to the animals. A simple machine for doing this is made as follows.

A shallow wooden trough on legs holds the straw. This is slowly pushed by hand to one end where there is a wheel with three curved blades. As the wheel is turned the straw is chopped and falls into a basket below, or for larger quantities onto the ground to be gathered up later. This machine is more useful for farmers who have many head of cattle and need to chop considerable amounts, or for chopping the material to fill a batch-loaded biogas plant.



A much simpler chopper is used by families with only two bulls for ploughing and one or two cows or buffaloes. Two strong strips of iron have a blade between them pivoted at one end and with a handle at the other. The straw is placed on the iron strips just below the blade, which is then brought down smartly cutting through the straw.

This appliance is very common. Almost every house with cattle has one. It serves also to chop up maize stalks, weeds, &c., for composting, and would do very well for chopping up material to fill a compost drum.

A VILLAGE THEODOLITE

For installing a water mill or a hydraulic ram a level is needed to measure the water head. A very simple yet quite satisfactory level for village use can be improvised with a wooden upright and cross piece to which is fixed a length of half-inch clear plastic pipe filled with coloured water. The water at both ends will always be level, even if the upright is not held quite vertical.

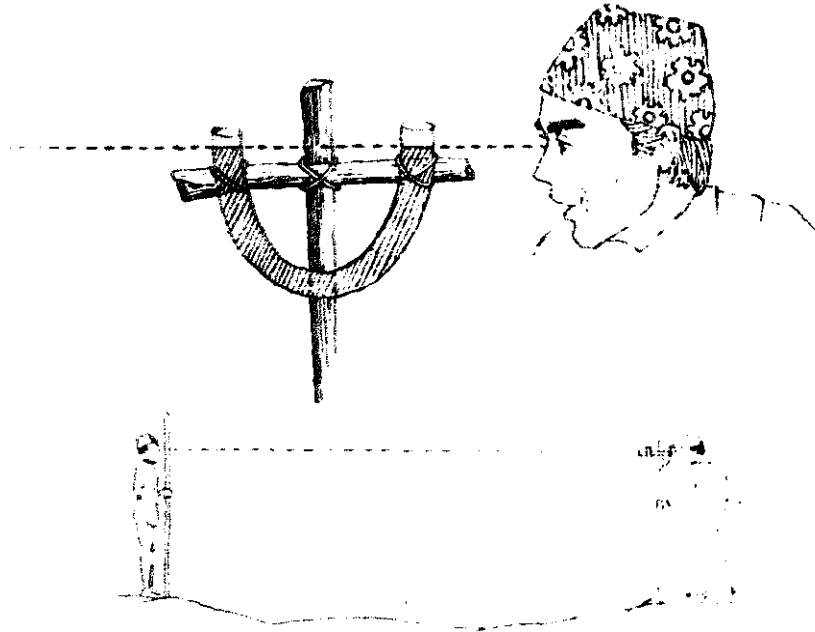

Source: UNICEF-Nepal

Here is another simple level. To an equilateral triangle of side 20 cm cut from a sheet of galvanized iron or stout tin is nailed a wooden strip 2.5 x 2.5 x 20 cm. Exactly in the middle, just below the wooden strip, a small hole is punched in the g.i. sheet through which it is nailed, loosely, to a wooden upright. In the bottom corner of the triangle another small hole is punched to attach a hanging weight. The reading is taken along the top of the strip. For greater accuracy, an eye screw can be fixed at either end of the strip with a very thin wire soldered across the hole. The reading is taken with the two wires in line.

THE KOREAN WINNOWER

To separate grain from chaff, the simplest means, with the hoariest tradition around the world, is to drop it slowly from head height and let the breeze blow the light chaff away while the heavier grain falls in a heap just below. This is the way it is normally done in all developing countries. It works fine - as long as there's a breeze.

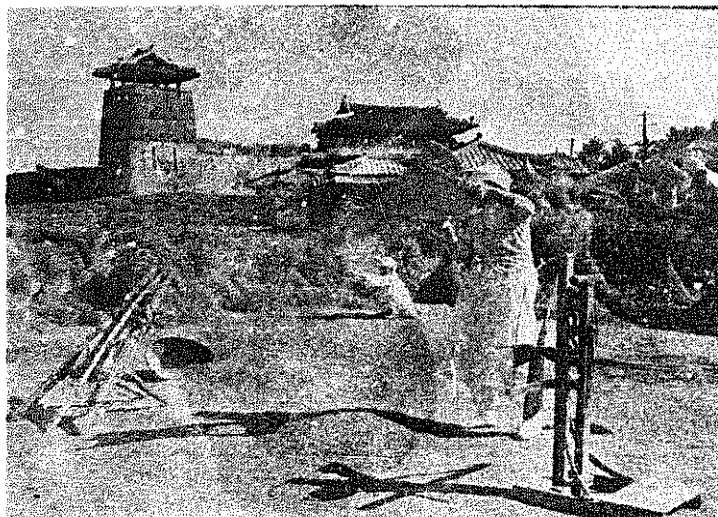

(Photo: Woojin, Korea)

Farmers in Korea winnow even on windless days by creating a breeze with a hand-operated fan. It has four blades resembling those of an electric ceiling fan fixed to a spindle with a small gear wheel from any broken down car. This engages with a large gear wheel turned by a hand crank. The gears and fan are mounted in a wooden framework. While Mrs. farmer handles the grain, her son has great fun working the fan and seeing how far he can blow the chaff.

This is only one step short of a box type winnowing machine in which the grain is placed in a hopper with a small hole below. The crank shakes the hopper and turns the fan. The chaff is blown out, and the grain falls into a sack placed underneath. All simple, neat, clean and efficient.

NEW HAND - HELD CORN SHELLER

A simple, efficient, hand-held corn sheller can be made of a strip of g.i. sheet, 35 x 13 cm.

On the g.i. sheet draw the design and mark off the folding lines as shown in the accompanying diagram. At the No. 1 lines bend the sheet carefully upwards, and at the No. 2 lines bend it downwards. Then bend the two ends to the interlock, hook them together and beat them flat. The sloping fins, of course, should be on the inside. That's all!

The corn is put in at the short fin end and is turned back and forth while being pushed further in. The freed grains of corn pour out and in a few seconds the cob is bare.

Any farmer who sees one of these corn shellers and handles it wants it. They are fast gaining in popularity.

THE "DHIKI" - A VERSATILE VILLAGE MORTAR

Where it originated we do not know, but it is very common in the Orient. It has been used for centuries to hull paddy, to flatten rice, to pound it into flour, or to make pulp.

It consists of a heavy hardwood beam about 150 cm long or slightly longer, some 15 cm broad and 10 or 12 cm thick. Near one end it has a wooden iron-tipped pestle, and near the other a pivot supported by two primitive U-shaped bearings usually stone. Below the pestle, sunk in the ground, is a stone mortar with a hole 15 to 20 cm deep and 10 cm in diameter. Inside the mortar is placed an iron cup, flat-bottomed or round-bottomed depending on the work to be done. The operator lifts the pestle by depressing the beam with his foot at the pivoted end and then lets it drop into the mortar.

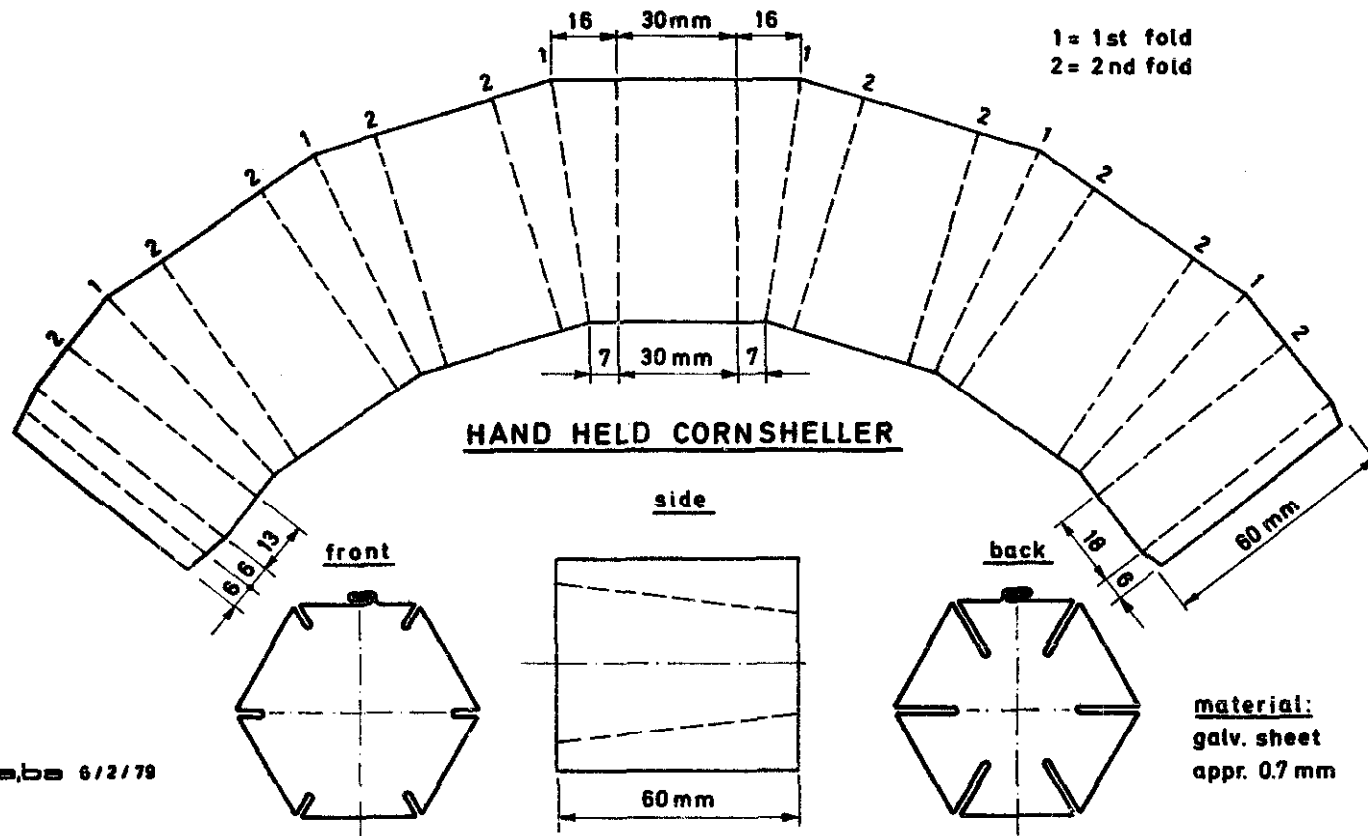

aba 6/2/79

For hulling, the paddy has to be quite dry. A flat-bottomed cup is used in the mortar. The pestle is fitted with a flat-bottomed sharp edged iron tip, which succeeds in cracking the hulls and releasing the grains of rice without crushing them. When half the amount of paddy in the mortar has been hulled the mortar is emptied and its contents separated into three parts: hulls, rice and paddy. The paddy is returned and the procedure repeated till all is hulled. Paddy splashing out of the mortar is pushed in again with a stick every stroke or two. This may be done by the operator himself (or rather herself, since it is generally women who do this work), or by a helper. The one who steps on the beam gets support by holding a post conveniently placed for the purpose, or a rope hanging from a rafter. After pounding, the grains of rice may still have traces of husk of them. A second pounding will detach these and yield perfectly clean, whole rice. However much the rice may be pounded it will not crack, provided the paddy was quite dry; but if it was damp, the grains will break up into small pieces. A bushel and a half of paddy may thus be hulled in a day's work.

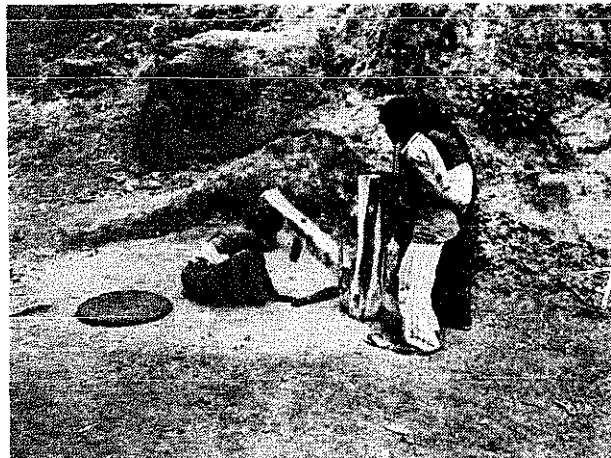

For making flattened rice (chiura) - Paddy is brought to a rolling boil, then dumped on a clean surface and left overnight to cool down and drip and dry. Then it is parched in a pot till it crackles and pops, when it is immediately pounded hard in a mortar. This detaches the husk and flattens the grain of rice. If the rice tends to cake, it must be constantly stirred with a bamboo spatula and the pounding continued. The mortar is then emptied, the chaff discarded, and the chiura stored in a dry, covered pot.

The pivot end of the beam is sloped on the under side from half its thickness to about 15 cm in length, and just below this a little pit or depression is dug in the ground. This enables the beam to rise higher before touching the ground.

Other agricultural produce, like tumeric, chillies and other spices can be reduced to powder in the mortar. To achieve this, the flat-bottomed cup is replaced by a round-bottomed one and the pestle is fitted with a rounded iron tip.

THE CARPENTER'S HORSE

If I hadn't seen with my own eyes the trouble carpenters take in some African villages to saw through lumber, I'd never have believed it. When they were shown the simple contraption used by carpenters all over south Asia, they were amazed and delighted. In the hope that village carpenters elsewhere in the world may be equally helped and delighted a description of the Asian tripod or trestle or "horse" is given below.

There are two strong lengths of wood, about 7 cm x 10 cm x 175 cm, fixed together near one end at an angle of approximately 30°. At about 15 cm and 30 cm from the other ends, pegs are driven right through. Near the pegs two adjustable supports or legs are attached.

The log or lumber to be cut is placed under the crossed end of the tripod. The upper end of the log rests on a cross piece between the pegs. The legs can be moved so as to adjust the height of the lumber to allow a sawyer to sit on the ground and work from below. A second sawyer can work and guide the saw from above if he stands on his tripod.

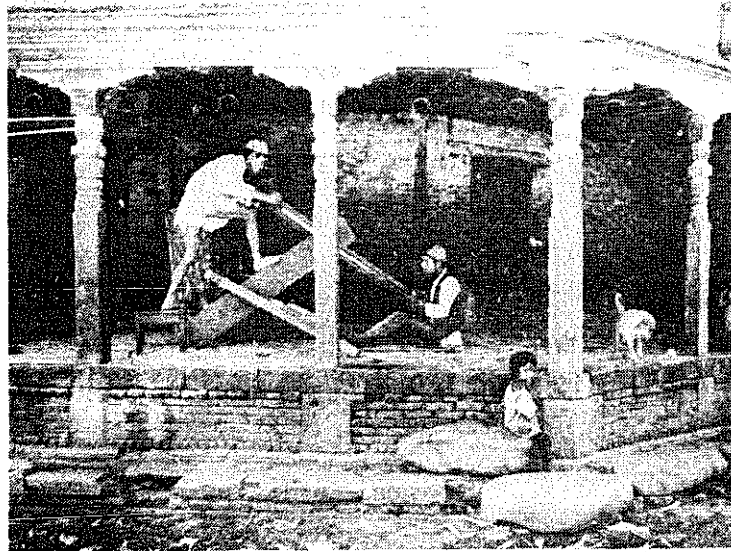
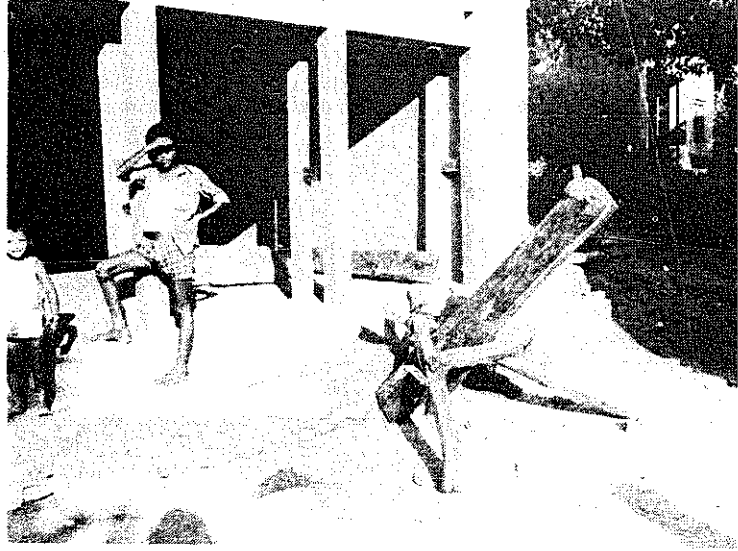

A SMALL BRICK OVEN
(Capacity: 8 pcs one-lb loaves)

- Mark off on the ground a square of one metre.
- Lay bricks within this space to a height of four to five layers.
- In the centre mark of a square of 50 cm. This space will be the oven floor. Make it as hard and compact and smooth as possible.
- Build up the sides and back to a height of 20 cm. Then make an arch with its apex 35 cm above the floor.
- In the front wall leave a door space 25 cm wide and 20 cm high. Fix a sheet-iron door in the brickwork.
- It is recommended to plaster the outside of the oven with a mixture of clay and cowdung (or chaff, or rice husk). This chars in course of time, leaving tiny air pockets in the plaster having an insulating effect which keeps the heat in.
- If the oven is out in the open and not under shelter, make the top slope down gently from the centre so that rain water may flow off easily.

That's all! Let the oven dry thoroughly before lighting a fire in it.

To use, fill the oven with firewood and light it. Leave the door and the smoke hole open. When the wood is consumed, close the smoke hole securely, pull out the embers, put in the bread placing the pans a little away from the sides, and close the door. In about 40 minutes the bread will be baked. The loaves are ready when they emit a hollow sound if tapped on the bottom.

Immediately after extracting the bread, the oven should still be hot enough to bake a batch of biscuits.

ANOTHER NEW NEPALI CHULO
(Modified "Magan" System)

Although many improved household stoves have been made over the last two decades in Nepal this kind of technology keeps on developing.

The common goals of people involved in improving household stoves are generally the improvement of fuel efficiency and creation of healthier environment for the inhabitants, both human beings and animal. Other goals are the use of local materials, low cost, easy installation, easy understanding of operation and last, but not least, the social acceptability.

The latest designs are based on a traditional technology -the prefabrication of stove components - by local potters and installation in homes by stove constructors.

Improvement to the traditional stove are more efficient internal dimension, a baffle to increase the heat efficiency and a chimney to lead smoke out of the house.

From the outside, the finished, improved stove does not appear different to the traditional stove, because the prefabricated parts are surrounded by local bricks or stones and coated with a layer of red mud plastering. The new stove made from burnt clay parts is three centimetres lower than the traditional stove. This leaves space for a thick topping of clay, that can be applied in such a way that holes for the cooking pots can be shaped to fit the pots closely.

Such an installation can be completed in a few hours, provided the materials: stove, clay pipes, etc., are made ready in advance. A set of these items costs at present Rs. 70/- to Rs. 80/- (U.S. \$ 6/ - 7/-), not counting the transportation charges.

It is hoped that after the stoves are widely accepted the house owners will then build stronger chimneys of bricks or stones.

The cooks will of course have to learn a little to operate these new stoves efficiently. Experience shows that this takes only a few days and that these new chulos are quite acceptable and are being recommended by the users to many others.

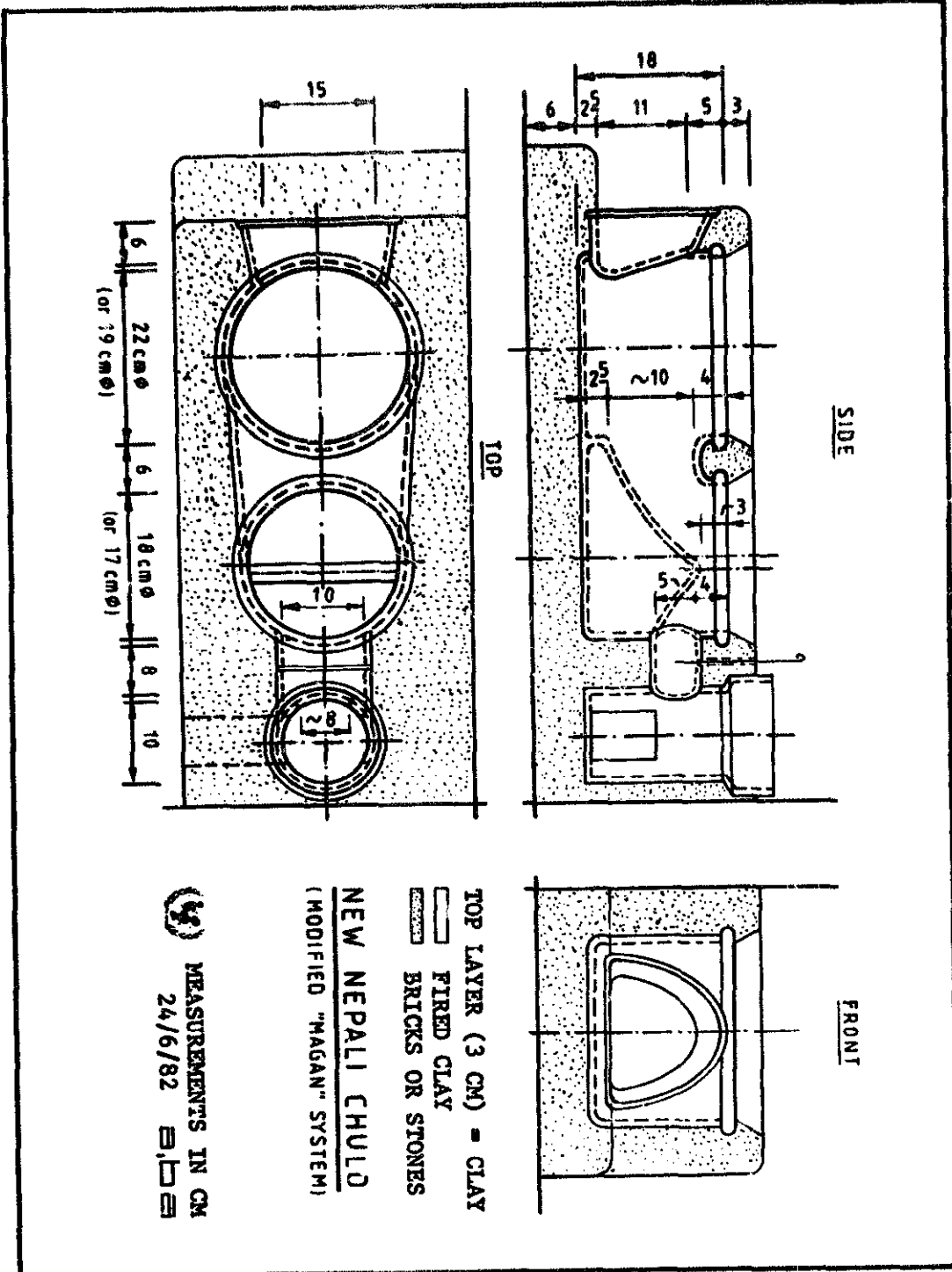

For efficient and comfortable cooking several points have to be followed:

- Dry wood cut in thin pieces should be used
- Slow cooking process is preferable
- Lids should be kept on cooking pots
- The damper should be closed as far as possible. However, for proper functioning the chimney should be at least handwarm.



Stove materials being made ready for installation in a Nepali village.



Trained installers at work in one of the rural kitchens.

Further information on such stoves may be obtained from: UNICEF, P.O. Box 1187, Kathmandu / Nepal, ask for booklet "New Nepali Cooking Stoves".

SMOKELESS KITCHENS

Chimneys are very convenient structures, provided they function properly. Correct chimney construction is a science in itself, with numerous variations possible. Fortunately there are also some rules of thumb that give satisfactory results.

The points mentioned here are for improved cooking stoves and room heating stoves. The rules for open fire places are not specified. In any case, those interested in efficient heating with wood will probably not be interested in open fire places.

1. Fuel Efficiency: Every stove connected to a chimney should have a draught regulator. This can be a damper or a butterfly valve in the connecting pipe between stove and chimney. Dry wood burns more efficiently than wood.
2. Temperature: The chimney needs to be warm for a good air draught and to reduce sooting. It can be insulated with fire resistant material (mineral wool), or be of special chimney building blocks (with hollow spaces for insulation), or in cooler climates, be built, for as possible, inside the house.
3. Materials: Suitable materials are those with retain heat well, such as bricks, stones, clay pipes, etc. Sheet metal (without insulation) may be used for radiation of heat inside the house, but should not be exposed to cold temperature outside, as fast cooling reduces the draught, and hastens soot formation inside the chimney.
4. Joints: Chimney pipes have to be well sealed for proper functioning, as well as protection against the risk of fire. Where bricks or stones are being used a mixture of clay and sand may be applied; pure cement is not suitable as it tends to crack when the temperature changes frequently.
5. Inside Surfaces: The inside surface of the chimney should be smooth and without any obstructions, so soot will not be deposited readily and cleaning is easier.

6. Foundations: Where the chimney is built of stone or brick one has to keep in mind that this structure is the "heaviest" part of the whole house! It rests on a comparatively small platform which carries the entire weight of the chimney which may pass through several floors. It is essential that chimneys be vertically!
7. Height of the Chimney: Wherever possible the chimney should be higher than the top of the roof, and in any case not be less than three metres in height, (if shorter, the draught may be reduced and combustion quality decreased).
8. Top: The upper end of the chimney has to be covered with a rainwater cap. It is of course essential to have a cap design that minimises the effect of wind which may cause back draught; a tee-piece is often used. It is easier to protect the roof from penetration by rainwater when the chimney passes through the roof at the ridge; here is less water than on the lower part of the roof.
9. Cleaning: Chimneys need regular cleaning. This can be done by using a brush attached to a stick, and by moving it through the chimney pipe from above and from below. It is wise to have an easily accessible opening at the bottom for the cleaning out of ashes and soot particles.
10. Sizes: Where bricks or stones are being used an inside square of 20 x 20 cm is very suitable for household applications. Where clay pipes or cement pipes are readily available they may be inserted in stone or brick structures which provide the required insulation. Where sheet metal pipes are being used a diameter of 100 mm i.d. is suitable.
11. Numbers of Connections: It is best to have a separate chimney pipe for each stove. It is also possible to have two or more stove connected to the same chimney, provided the chimney size is increased accordingly and the branches are at different levels.

12. Before lighting a fire in a stove: A good draught depends on a certain minimum of a fire in a stove, respectively of a certain temperature inside the chimney. It may be worthwhile to light a newspaper at the smoke exit inside the stove near the chimney, especially when the chimney is cold.
13. Danger: Chimneys are also dangerous! To prevent chimney fires regular cleaning is a must (every three to four months, approximately). Foundations and joints must be airtight and strong. Fireplaces must not be completely sealed off from the chimney draught. The damper should have gaps or holes; an almost dead fire can produce enough poisonous gas to kill a whole family in a quite closed room!

Well designed and properly constructed chimneys can greatly reduce the discomfort caused by smoke. Smoke is a problem encountered especially in the homes of poorer people. It is hoped these notes encourage the construction of effective chimneys, thus leading to a healthier environment.

THE HWOGWO

Who has not heard of the *samovar*? It's the Russian appliance for preparing tea. What is not commonly known, however, is that the fuel for boiling the water is right inside the water pot. Or looking at another way, the water is all around the stove. This is very efficient, because heat radiation from the sides of the stove is not lost on the air but is utilized in heating the water.

The same principle applies in what the North Chinese and the Mongolians know as the *hwogwo*. The word simply means "cooking pot", the most ordinary kind of cooking pot used by the common people living in those parts. Some Tibetans in Kathmandu also use the *hwogwo*, but they call it *jakok*.

The simplest way of describing the *hwogwo* or *jakok* is to call it a sophisticated *karai* with a chimney in the middle. A *karai*, for those who do not know the Nepali word, is a pot shaped like the segment of a globe. It is generally

of iron or aluminium. To convert a karai into a hwogwo, cut a 10 cm hole in the bottom and weld it to a conical tube or chimney tapering to a 7 cm hole on top. The cover too has a hole in the center to allow the chimney to protrude some 3 to 5 cm above it. Of course the hwogwo does not have to look like a karai. It could very well be shaped like almost every cooking pot.

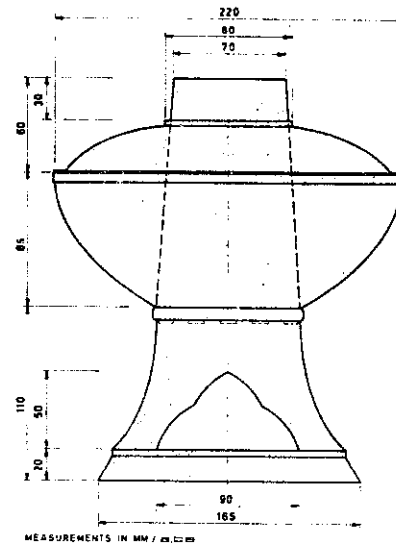

Inside the chimney, at the very bottom, comes a grating to support bits of charcoal, coke, wood chips or other similar fuel. The fire is lighted in, and is totally contained by, the chimney, thus applying all its heat to the very centre of the food being cooked. The pot rests on a stand with an opening in front through which the fire draws the air it needs. Some hwogwos have artistically decorated stands.

The little heat that passes straight up the middle of the chimney without touching the sides need not be wasted. With a samovar it is standard practice to place above the chimney a pot containing tea concentrate, which can thus be kept hot all day long. Nothing prevents one from supporting a small kettle above the hwogwo chimney so that no heat whatever be lost.

COOKING STOVES COMBINED WITH HOT WATER PRODUCTION

Hot water from a tap can be an added convenience for a home. Where wood or coal is used as a fuel for cooking a quite simple modification can be made to supply cheap hot water. It increases the safety of the household as hot water does not have to be moved around in pots.

Such installations are very popular in many countries, such as America, New Zealand, Switzerland, etc. The technology is well proven and sizes ranging from small to large are available.

The system works in the following manner: To the side walls, out of the way of the firewood, of the fire chamber a water jacket is fixed, in which the fire heats water. Out of this box or pipe coil two pipes are lead to a hot water storage tanke fixed above the stove. One pipe, the "riser", goes from the top of the water jacket to the top of the storage tank. The other pipe goes from the base of the heat jacket to the base of the storage tank.

When the fire is lit, warm water in the water jacket is displaced by colder, denser water from the storage tank, and circulation of the water between the water jacket and the storage tank starts.

A well-insulated hot water storage tank will easily remain hot overnight, provided the tank is fixed 60 cm higher than the top of the stove. This height difference is necessary to prevent backflow and cooling in the un-insulated water jacket.

To make a system that works properly note the following:

- The system has to be designed and installed so that the heat exchanger will remain filled with water during heating.
- Careful attention has to be given to proper installation; all the circulation pipes (connections between stove and hot water storage tank) must be fixed with a gradient towards the hot water storage tank; a "breather pipe" must be attached to the top of the storage tank.
DANGER: it is extremely dangerous to have air locks in the pipes: the heated water will transform into steam where air bubbles are and may cause an explosion.

- Heat exchanger to be of welded construction; where pipes are used the seamless steam pipes are recommended and should not be less than 3/4" diameter. Where possible the coil should be made from one piece of pipe. The coil can be made by filling the pipe with and bend it over a fire. If fittings are needed, they should be of mild steel and welded; screwed joints will leak as the fire will burn out the jute. The water jacket can also be made of strong M.S. sheet with welded joints.
- Make sure that the circulation pipes are properly fixed: upper pipe of heat exchanger to upper connection of the hot water storage tank (at least 2/3 of total height of the hot water storage tank). The lower pipe of the water jacket to the lower connection of hot water storage tank. These pipes need to be insulated only where they are longer than approx. 1,5 mtr. Note: no valve of course should be fixed in the circulation pipes, for safety reasons.
- It is essential to provide the hot water storage tank with a safety device, so that the heated water can expand without troubles. There must be a safety valve or a vent.- pipe, etc.
- The pipe that draws off hot water from the system should be fixed to the top of the hot water storage tank, so that the hottest water can be tapped.
- Where danger of freezing exists it is necessary to drain the system. Empty the hot water storage tank, keep the taps open and keep the firing going until the water jacket has dried out. There may also be a drain valve outside the stove for convenient draining of the heat exchanger.
Note: before lighting the fire again, the system has to be filled with water; firing without water will quickly damage the water jacket.

A simpler device is used in Africa. The metal chimney pipe is surrounded with a jacket, which is filled with water. A tap is fixed at the bottom to drain the heated water. The system will provide good service for warm water, however, one has also to consider that one can not extract all the heat in the smoke for heating the water (otherwise the gases may condens and soot be deposited in the chimney. These systems, properly installed, usually give complete user satisfaction.

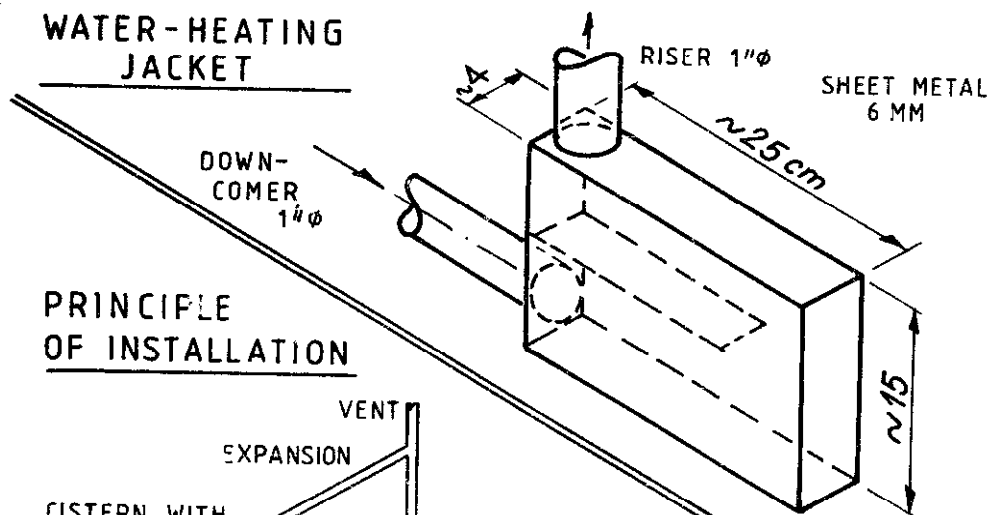

PRINCIPLE OF INSTALLATION

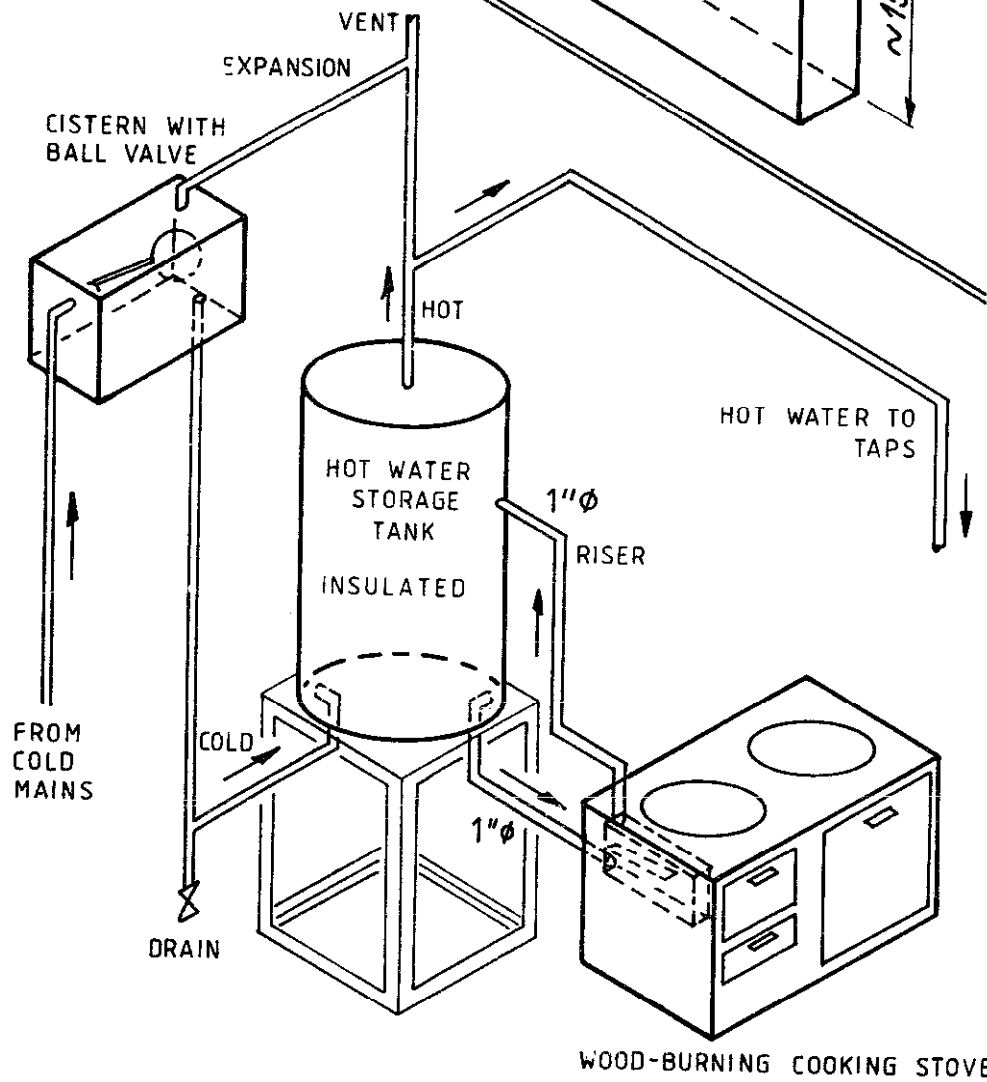

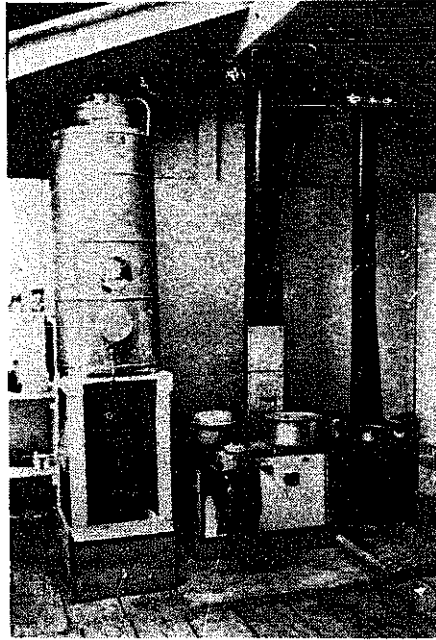

The picture shows the installation at the Phaphlu Hospital. This combination enables the cooking with wood, the heating of water, (there are also connections to the solar collectors).

The equipment has been imported from New Zealand.

A prototype of a new Nepali cooking stove. The door, grate, top plates with rings are locally made of cast iron by:
 Kathmandu Metal Industry
 12/514 Quadon, Nagal
 and
 National Structure Engineering Company
 Patan Industrial Est.
 Lagankhel, Kathmandu

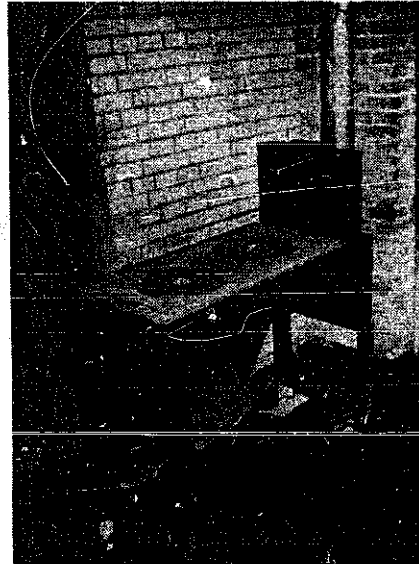

Valuable information on application of cast iron stove assembly may be obtained from the book: "Modern Stoves for all", by Wacław Micuta, 1981, available: Bellerive Foundation, P.O. Box 6 CH- 1211 Geneva / Switzerland

FIGHTING THE BUGS
Death to Anopheles!

The absence of smoke in a house, for example as a result of smokeless cooking stoves, mosquitoes attack the occupants and wood borers may attack the rafters.

Mr. Alladin of Hyderabad (India) informs us that the female mosquito, after sucking our blood, flies out and lays her eggs in any nearby patch of stagnant water. So the thing to do, as is done in Africa, is to supply her with a number of shallow pans of water mixed with a little dung or urine for greater attraction. She gladly lays her eggs in these, and next morning you empty the pans onto dry sand in full sun where the eggs frizzle up and perish. This repeated again and again helps free the hole neighbourhood of future generations of mosquitoes.

Insect Repellant: To discourage mosquitoes (as well as bed bugs and fleas) from coming after your blood, make up the following repellent and smear it all over all exposed parts of your body.

- Kerosene oil 100 parts
- Any edible oil 1 part
- Powdered naphthalene 5 parts
- Eucalyptus oil 1 part

Mix all ingredients and agitate till completely blended.

Mixture against wood borers: Mix all ingredients and store airtight. Brush onto rafters lavishly in every nook and cranny. For a new house, before erecting the rafters soak them in a five percent solution of copper sulphate in water, so that the poison sinks well into the wood. No insect will touch it. One application is enough.

- Kerosene 100 parts
- Liquid coal tar 5 parts
- DDT powder 5 parts
- Boiled linsed oil 5 parts

Apply the above mentioned mixture once a month.

SHEET METAL PIPES

When a village blacksmith attempts to make a metal chimney or a rain pipe he bends a sheet of metal by hand, forcing it into shape little by little, and ends up with a tube that is more or less even, and may or may not have the same diameter at both ends. If he uses the appliance described below, he will produce a perfect pipe, smooth, straight and accurate.

All he needs is a block of wood as long as the section of the pipe he intends to make and a wooden roller slightly longer. In one bottom corner of the block a 45° cut, about 1 cm deep, is made along the whole length. This helps to crimp the two edges of the metal sheet to form the join. The sheet is then placed on the block and gently pressed down with the roller. Pressing it only a little gives a bigger curve for larger diameter tubes. For smaller diameters it is pressed further down. Then the two edges are hooked together and beaten flat. The result is an almost perfect pipe that any blacksmith can be proud of.

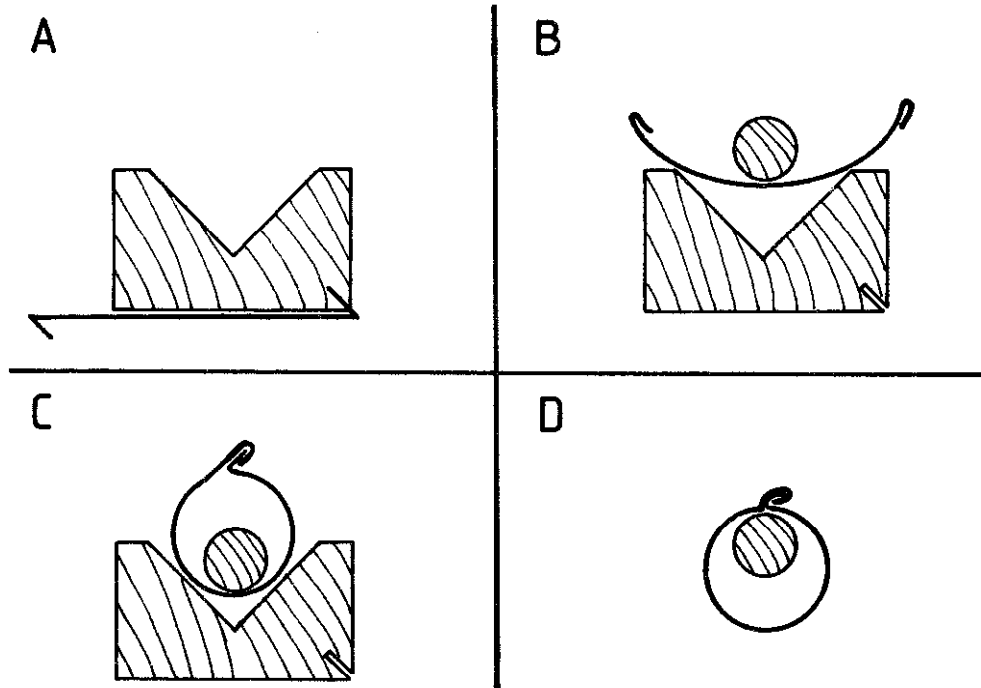

(Source: VITA)

HAY - BOX COOKING

Have you ever cooked with hay? Now don't get the wrong idea. Poor people often use dry leaves or straw as fuel for cooking; but we are not recommending that we burn grass in our stoves. Hay, after all, is only cut grass. But have you noticed how a pile of cut grass heats up? No, not hot enough of course to cook a meal in a few minutes. But quite hot to help.

Poor villagers in Europe have used the hay box for centuries to cut down expenses by saving fuel. New-mown hay is put into a large box, a hole or kind of nest is made in the middle leaving several inches of hay all round at the bottom. Then a pot of food is brought just up to the boiling point, covered, and immediately placed in the nest. A cushion is placed on top to prevent the heat from escaping. After some time, from half an hour to several hours depending on what is being cooked (meat for example takes longer than rice), the pot is withdrawn and the food is ready to be eaten.

Instead of using hay we can make our hay box with any insulating material. First put a couple of sheets of newspaper inside along the four sides and at the bottom. Then put in at least 10 cm of insulating material all round and below, leaving a nest in the middle lined again with paper and large enough to hold your pot snugly, but a little deeper to allow for a cushion above. As insulation we may use either fresh hay or dry grass, chopped straw, bits of crumpled paper, coir, cotton, sawdust, or if you can get it, glass wool. Some people use polystyrene, which is perhaps the best?

Fresh hay, besides insulating, generates its own heat, but the other materials named above do not. So with these kinds of insulation it is advisable to place below the pot a flat heated stone or brick. Space for this should be made so that the pot can be well sunk into the insulation. The pot should also be quite full. So the size of the pot to use depends on the amount of food being cooked.

For cooking rice, put rice and water into the pot as usual; bring it just to the boil, then put the full pot covered into the nest with the hot stone below and the cushion above, close the box with its lid, and in twenty minutes your rice will be ready. Meat requires 20 or 30

minutes' cooking on the stove before being placed in the box. If the night meal is prepared in the morning and placed in the box, it will be ready to eat in the late afternoon or evening. Or the morning meal can be prepared and boxed overnight to be ready when you awake next morning.

What is the advantage of a hay box? Well, instead of bringing your rice to the boil and adding more and more fuel while the pot continues to boil till the rice is soft and quite cooked, you put in the hay box and save all that extra fuel. Or you cook some other dish with the fuel that would have been used only to cook the rice. So the hay box economizes on fuel, and a little saved energy every day means a lot saved in a month; and that is really worthwhile.

MUSHROOM CULTIVATION

The method of mushroom cultivation described below is extremely simple. It does not call for any compost or horse manure or fancy fertilizers. All that is needed is paddy straw and mushroom spawn, water shade and warmth.

The mushrooms are grown in "piles" rather than in boxes or "beds". For each pile about 25 kg of fresh paddy straw are needed. The straw is made up into loose bundles of about 15 cm diameter and any convenient uniform length. The ends are clipped straight. All the bundles are soaked in water overnight. Next morning the water is pressed out and the damp bundles are laid side by side in the shade on a mud or brick platform some 10 cm above ground level about 1.5 metres in length and as wide as the straw is long.

The spawn is taken from the packet or bottle and laid on the surface of the straw in thumbnail size blobs 10 cm apart, along the perimeter only, and 5 cm from the edges. Nothing is put in the middle. Another layer of straw bundles is then placed compactly over the first and spawned in the same way. The pile is thus built up and spawned, layer upon layer, to a height of five layers. On the fifth layer spawn is placed not only along the perimeter but also in the middle. A sixth and last layer is then placed on the pile but is not spawned.

Trim the edges of the pile neatly. Now water it till the water begins to drip off. Cover the straw (top only) with wet sacks, or a sheet of plastic, or both. The purpose is to keep the pile damp.

Once the pile is built up, spawned and covered, no further attention is required beyond seeing that the straw is maintained in a damp (not soggy) condition. When sprouting begins the covering may be removed. Depending on the variety of mushroom and on the temperature, it takes from a fortnight to a month for the mushrooms to be ready to harvest. They are picked when the tops are round and plump and before they begin to open and flatten out. To harvest, place a finger below the root and draw the whole plant out. Don't break the stem off.

If well grown and carefully harvested, the mushrooms continue sprouting for a week or ten days. They will remain good for about two days after picking without any special care. To store them for a longer period, steep them in salt water and dry them in the sun. They will then remain good for up to three weeks. To restore to fresh condition before eating, soak them in fresh water.

Each pile, depending on its dimensions and the success of its cultivation, commonly yields about 3 kg of mushrooms, which sell in India at Rs. 35/- (appr. US\$ 4.00) a kilo. They are in great demand at high class five-star hotels that can well afford to pay good prices.

Straw once used for mushrooms should not be re-used. Always make the piles with fresh straw not more than one year old. Besides paddy straw, millet straw may be used. Wheat straw has not been tried. Dried water hyacinth will also do, and so will banana leaves that have dried on the plant and not touched the ground. Straw that falls on the ground when trimming the pile should be discarded: it is contaminated.

Two varieties of mushrooms commonly called "Paddy-Straw Mushroom" are particularly recommended:

- *Pleurotus*, for a temperature range of 25° - 30°C
- *Volvariella*, for a temperature range of 25° - 35°C

Spawn for these varieties is propagated and sold at many Universities in India. Apply to the Department of Mycology of the University's College of Agriculture.

FLYING FOXES

Flying Foxes (in some places called "fruit bats") are a menace to fruit orchards. During the daytime they take possession of any tall tree and hang upside down from its branches, like any bat. A hundred or more may live on a single tree. A little after dusk they fly off to an orchard where the fruit is ripe, or nearly ripe, and gorge themselves, to the dismay of the owner. In India a way of catching them has been in use since as far back down the centuries as anyone can remember.

Tall bamboo poles, slightly taller than the fruit trees, are fixed on the side from which the birds come. From these is hung a string net with a wide mesh, say 10 cm. This must foil their inbuilt radar, because they always fly smack into the net, where they get entangled, thanks to the many hooks on their wings. The owner distangles them and takes them home for his dinner. Since they live on only fruit no one objects to eating their meat. However, the cook must be careful not to let their fur, a lovely, soft, grey-brown fur, touch the meat as it imparts a foul smell which would render the food objectionable.

RABBIT REARING FOR VILLAGERS

It is a known fact that tame rabbits convert food into meat more efficiently than pigs, poultry or cattle; and their meat is tasty as chicken. Farmers in Nigeria can obtain rabbits for rearing at home from eighteen Government breeding centres. West Germany produces 20,000 tons of domestic rabbit meat a year. The island of Mauritius follows a programme like Nigeria's. Rabbit breeding in villages is being successfully propagated in India, especially around Secundarabad. And what about Nepal?

The method of rabbit breeding advocated here is not geared to wholesale breeding on a commercial scale. It is intended merely to increase the protein consumption of villagers by providing each family with one rabbit a week for table throughout the year. That means three or four kg meat a week.

The hutches, of which only two are needed per family, can be made entirely of bamboo, so no expense is involved beyond perhaps the cost of bamboo, no wood, no nails, no wire screening; though of course these materials could be used if desired. Split bamboo is used (or whole *ningalos*) with the shiny side towards the rabbits so that they can not nibble it easily. The strips of bamboo making the floor should be just far enough apart to let the dung drop through. The dung makes manure, and the pelts make soft babies' caps and jackets.

Only two does are required, one on each side of the breeding hutch, separated by the breeding boxes. The buck is kept in the centre of the second hutch, with the grown offspring of the does, males on one side and females on the other.



(Photo: Julian I. Gonsalves,
Secundarabad / India)

A does can be mated when six months old. Gestation takes about a month. The young are left with the mother for two months and are then removed, the males being separated from the females. If left together too long, the immature young male try to mate with the females and spoil them for life.

The young are ready to be eaten when four months old. One way to kill them is to hold them up by the ears and strike sharply on the nape of the neck with a stout stick.

If the does are mated every three months, they will produce four litters a year with six to eight young per litter. That makes some twenty-six young a year from each doe. For mating it is important to put the doe with the buck and not vice versa: she resents her domain being intruded upon by an outsider and may refuse to accept him. Does are fertile most days of the month and infertile for only a few. If mating does not occur immediately (within an hour) try again in a couple of days.

Rabbits are fed on grass, leaves and little grain (wheat, maize, paddy). They should also be given water, and a lump of salt, which they like to lick occasionally. If you feed your rabbits well, they will grow strong and plump, will produce good litters, and will feed you well in return. To maintain the rabbits in good health it is essential that the hutches and their surroundings be kept clean and dry, that they have good (but not draughty) ventilation, and be in the shade on the warm, sunny side of the house.

The wrong way to hold a rabbit is to pick it up by the ears. It should be held with its haunches resting on one hand, while the other hand holds it by the loose skin behind the neck.

One inviolable rule is that young rabbits should never be taken out to play with and not be let run about the room. If they escape they are very hard to catch, and fall an easy pray to dogs and cats. Such baby rabbits that have been handled are rejected by the mother.

In India villagers are given a short course in rabbit rearing. Those who show sufficient interest and prove their determination to go ahead by actually making a hutch, are presented with two mated does, which they later return. The scheme is thus self propagating. If this plan could be followed in Nepal the villagers would obtain regular supplies of meat at the cost of a minimum amount of care and attention.

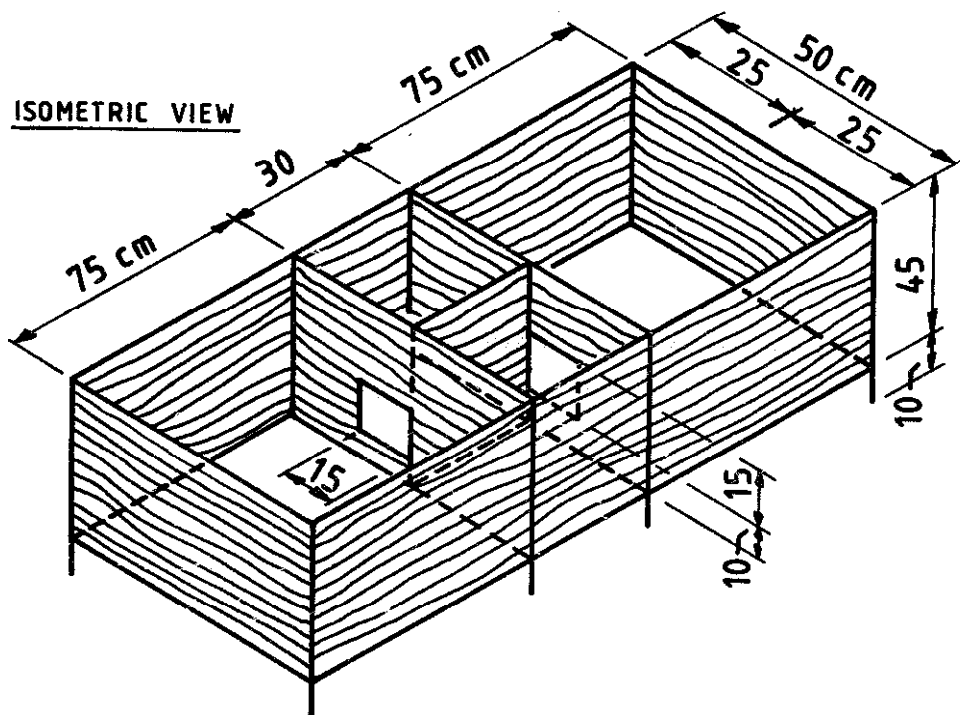

TOP

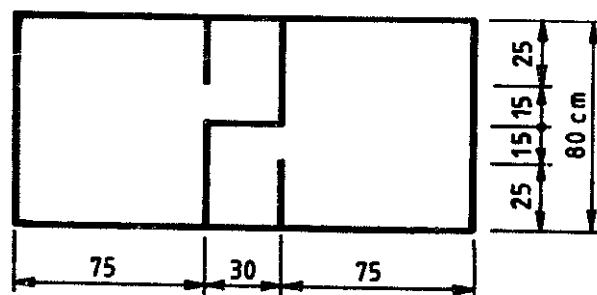

GINGER ALE

a delicious alcohol-free beverage

Put into a pot sugar, grated ginger, cream of tartar and the outer coloured portion of the lemon rind thinly shaved off, and cover with boiling water. Stir till sugar dissolves. When cool, add lemon juice and yeast (dissolved). Stir, strain, bottle and cap tight immediately. Store a room temperature for a week or ten days before drinking. In warm weather three or four days is enough.

- 100gm root ginger
- 1 lemon
- 40gm sugar
- 1 Tbs cream or tartar
- 5 lit water
- ¼ tsp baker's yeast

This recipe makes a delicious, dry ginger ale, much like Canada Dry, which goes well with whiskey instead of soda. Since it contains only enough sugar to carbonate, the bottles may be stored indefinitely without the least fear of their bursting. If the ginger ale is preferred slightly sweet, add 4 tablets saccharin per liter before bottling and capping.

The quantity of ginger recommended in the recipe is only by way of guidance. More may be used or less to suit the drinker's taste. Besides, fresh root and old half-shrivelled root are not equally strong. For still greater strength boil the grated root ten or fifteen minutes instead of merely infusing it in boiling water.

"Cheers!" "A votre santé!" "Skoa!" "A la sua salute!" "Nazhdorovye!" "Zum Wohl!" or however else you like to say it.

COMPOST - MAKING DRUM

Fill your flower pots and garden beds with rich compost and you will be rewarded with strong healthy plants bearing rich green leaves, abundant lovely blooms and luscious vegetables. You won't have to buy chemical fertilizer. The raw material is provided by the grass clippings from your lawn, all the soft weeds you find (no woody stems), and all the organic garbage from your kitchen: potato peels, peanut shells, fruit peels, inedible vegetable tops, green leaves, all left-over waste. All this is put into the drum described below, given two or three rotations once a day, and within three weeks your drum will give you rich, soft spongy, nourishing humus. Just what your plants have been yearning for!

In the top and bottom of a diesel oil drum, right in the centre, drill a hole just large enough to take a 1/2" iron rod. Lay the drum on its side and cut a square opening of 24 cm between the ridges. Over this fix a metal cover hinged on one side. This is the opening through which the drum is loaded and the humus extracted. In the top and bottom of the drum drill about 15 1/2" holes for air. Air is necessary for the microbes to thrive and decompose the organic matter.

The drum is supported on a wooden trestle with a leg spread slightly greater than the drum diameter, and of convenient height for filling and turning the drum while leaving sufficient room below to accommodate a bucket or a basket or wheel barrow for drawing off the compost. The drum can be turned either with a crank on the centre rod or simply by hand, especially if the rod is mounted in bearings, though it turns quite well without. The measurements we give will suit a drum of 86 cm length and 58 cm diameter.

The material to be composted should all be shredded or chopped up into small 1" pieces. Whole leaves and large weeds do not break down easily. It is recommended not to add cowdung as this has a tendency to form into lumps that do not compost well. Load the drum with matter that is moist but not soggy, filling it to about half its volume. Give the drum two or three turns once a day. In a couple of days the contents of the drum will heat up. This is a sign that the microbes are happy and working well. They generate such a lot of heat that weed seeds and flies' eggs are all cooked and killed.

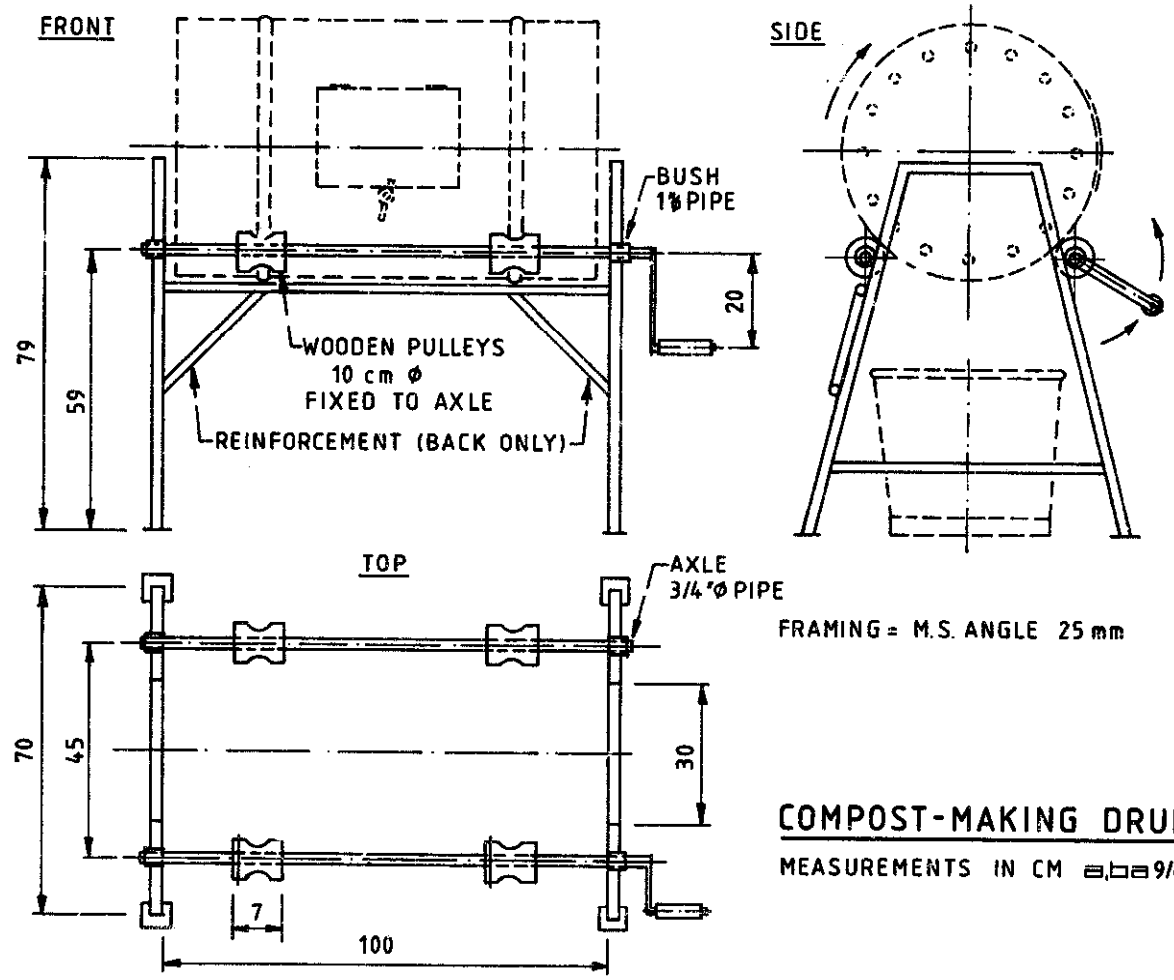

COMPOST-MAKING DRUM
MEASUREMENTS IN CM 2,22/82

During the fortnight that the compost is forming, kitchen waste can profitably be dumped into another drum or a metal garbage can with a close fitting cover to eliminate smell and flies. By the time the compost drum is already partly decomposed and ready to be loaded into the compost drum. Its composting is thus speeded up. Grass clippings and weeds can be added at this time.



PRESERVING FLOWERS

Flowers can be preserved to last for months and even several years, fresh and bright, in their natural tints and perfect shapes, so true to life in fact that your friends, and even yourself, will not be able to distinguish them from living blooms except by touch.

The process is an old one. It consists on drying the moisture out of a flower by burying it in sand without damaging it in the least. With the right kind of sand, properly prepared, the flowers can be completely dried out in a fortnight.

Sand with sharp, jagged edges, the kind recommended for mixing concrete, is the wrong kind for preserving flowers. For this purpose the sand should be round-edged, soft, chalky, absorbent. It is given an initial, rough washing to remove gross foreign matter like rootlets, shells, and so forth. Then it is washed again thoroughly in soap water, after which it is rinsed again and again and again (two dozen times is not too often) in clean, fresh water to remove even the faintest traces of salt, soap or chemicals. The next step is to boil it in order to kill bacteria that might eat into the petals and damage them. Then it is dried, out in the open sun, or better still in an oven. Last of all it is sieved, the finer the better. The sand is now clean and dry, fine and free-flowing; it is ready for use.

You will need containers. Any kind will do: wooden boxes, mud pots, plastic bottles, glass jars, tin cans, drinking cups, anything large enough to bury a flower. Pour four or five centimeters of sand into the container. Holding the flower by the stem (don't touch the petals or you may rub off the delicate bloom and leave finger prints), stand it in the sand, right side up. Pour more sand in till it reaches the petals, then gently fill up, under, in between, and over the petals, taking care to cushion the flower without forcing it even a little out of its natural shape. Tap or jiggle the container gently so that sand trickles into every little open space and no air pockets remain. Pour more sand in over the place, duly labelled and dated, so that you know which bloom is where, and when it will be ready.

A fortnight later tilt the container and ease the sand out uncovering the flower little by little. As soon as the stem appears, hold it with tweezers and gently pull the flower out and stand it up in sand: don't lay it flat on any hard surface. Be careful always to handle the bloom by the stem; avoid touching the petals. Any sand that doesn't easily shake off can be gently brushed off with a soft camel-hair brush.

By far the best way to display the dried flowers is to mount them on their own natural stems, which should be selected and kept apart at the time of sanding the flowers. The stems are dried by leaving them exposed in the open air. They will lose their colour on drying so to have be painted in their natural shade of green. For every flower preserved, one or two leaves also should be sand dried.

The leaves and flowers are fixed to the stem with the aid of tooth-picks. If very small and light, the leaves may be stuck on with a drop of collodin or nail polish.

Put two or three of your artistically mounted flowers in a vase of sand (no water of course) and place it on a shelf or table. Anyone entering the room will think that they have just been picked from your garden. The illusion can be heightened by putting a drop or two of appropriate perfume in or near the vase.

A word of caution: remember that in dehydrating the flower the sand has absorbed moisture. So dry it out again before you re-use it for another flower. While most flowers can be processed satisfactorily, some few fail every time. Irises, for example, no one knows why, lose all colour and become glassy. Poppies are too delicate: they just fall apart. Begin working with sturdier blooms like tulips, daisies, zinnias, dahlias, hollyhocks, roses. These come well. You will then enjoy the thrill of success from the very start.

A WATER SCOOP

A universal problem with public water supply is that users carelessly leave the tap open, thus wasting enormous amounts of filtered drinking water. Automatic taps that close on release, whether by gravity or with a spring, hardly help because they are often tied open. A hand-operated suction pump is good until, with constant wear, the various moving parts wobble and rattle and finally fall apart.

Here is a method of drawing water that has only one very simple moving part, a scoop attached to a length of 1" water pipe that acts as a handle. When the handle is depressed, the scoop picks up water and lets it flow out through the handle. The scoop and handle are fixed in a small water tank with a ball valve.

AN ODOURLESS PIT PRIVY

By far the simplest, neatest and most efficient odourless pit privy design we have ever seen is what is known as the Blair Ventilated Privy. It was developed by the Blair Research Laboratory, Salisbury, Zimbabwe, and was tested for two years before being recommended to the public. It has proved so efficient that now there are tens of thousands in use all over the country.

The privy is a simple pit, three or more metres deep, depending on the number of users. It is recommended to allow a volume of 1 m³ per person. The upper portion has a brick or concrete collar covered with a concrete slab having an oval squatting hole to take a pipe of 15 cm i.d. The wall of the cubicle is built in a spiral of brickwork or of corrugated iron plastered over, with chicken wire holding the plaster. It is roofed with a thin concrete slab. There is no door.

The vent pipe, 2.5 m long, rises higher than the privy roof and ends in an inverted conical top. (20 cm i.d.) protected with a piece of copper or fibreglass fly screening (g.i. screen corrodes). The pipe should be ideally be on the sunny side of the spiral, i.e. towards the Equator, and should be painted black so that it can be better heated by the sun. This heat together with the natural heat in the pit causes a convection current which draws air down through the squatting hole and up through the vent. It is this constant automatic ventilation that frees the privy of fould odours. A slight breeze over the vent will also cause an upward airflow within it.

The inside of the structure is painted a dark colour; thus the only bright light entering the pit comes through the vent pipe. Any fly in the pit are attracted to the light, and since they cannot escape they ultimately die and fall back into the pit. Water is not required in this pit privy, though it may be used and is even helpful in small quantities. There is also no need to put any earth or sand after each use, as is commonly done in a bore-hole latrine.

Any pit toilet should not be built within 50 m of a drinking water well or above a drinking water stream or spring for fear of polluting it. The bottom of the pit should be above the ground water table (Monsoon level).

It is good to check the vent pipe screen occasionally to keep it clean of cobwebs, dead leaves or other obstruction.

Since the pit fills at the rate of about 87 litres (3 cft) per person per year, with a capacity of 1 m^3 per person it will take 12 years before needing renewal or replacement. When the contents come about to a foot from the orifice, the pit should be covered with earth. A year later the contents can be dug out. They will be completely decomposed and make an excellent fertilizer and soil conditioner.

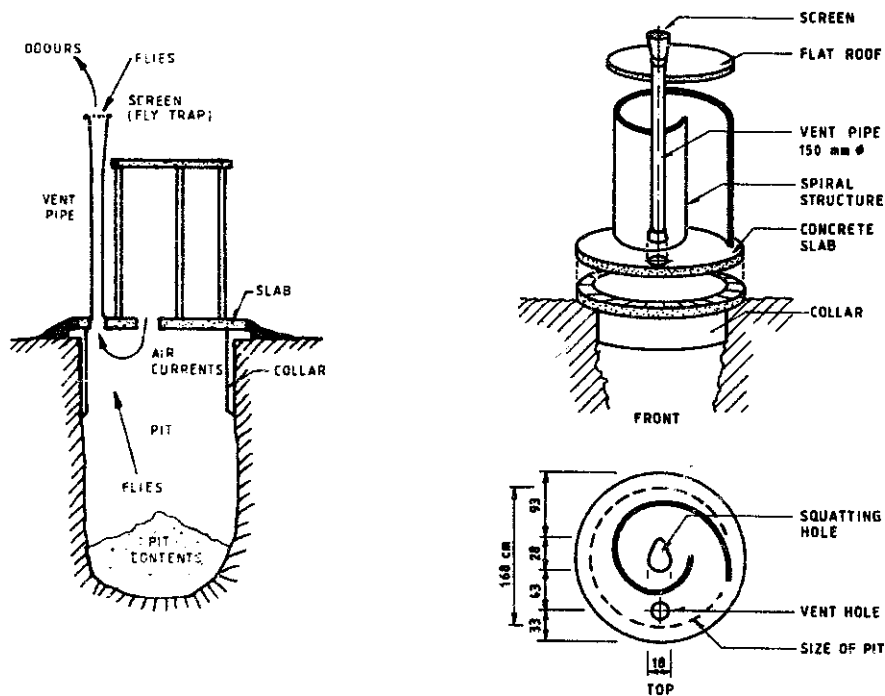

It is recommended that detailed building instructions be obtained from: Blair Research Laboratory, Post Box 8105, Salisbury, Zimbabwe.

USES FOR BURNT - OUT BULBS

What can one do with burnt-out bulbs? Here are a few suggestions.

In India they are frequently used as containers for indoor plants. One often sees the Money Plant (*Philendron scandens*) growing in a bulb filled with water (no soil). It hangs down gracefully, and if supported will trail right round the room. Another plant that grows well in a bulb is The Wandering Jew (*Zebrina pendula*) but this like most other requires a good spongy potting medium.

Others that you may like to try are Swedish ivy, Quamoclit, Maidenhair, the tiny begonia semper folrens, Columnea gloriosa, Asparagus Plumosus nana. And this is not a complete list.

Discarded bulbs can make pretty Christmas tree decorations. The bulb are cleaned out free of all dirt or grease. Then a thin gelatine solution in water is swished about inside with a very little glycerine added to prevent the thin coat of gelatine from cracking when it dries out. It is then tinted with any water soluble aniline colour, red, green, yellow, blue.

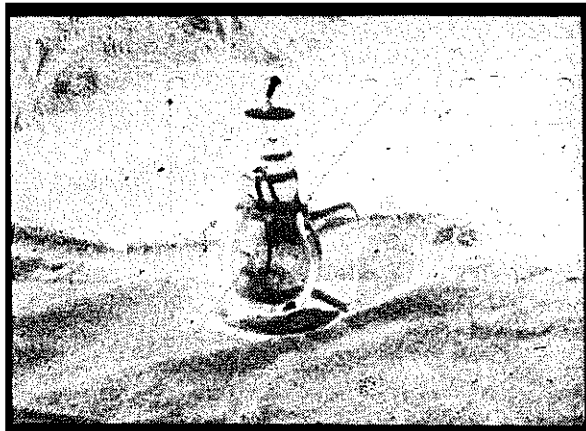

In Sri Lanka little night lights are made from old bulbs. They are fixed to a tin base. A small tin cap is placed on top with a hole in the center for taking a wick. Then the bulb is filled with kerosene and lighted. A better model may have a small glass chimney. These are easily available in India.

SNAILS

Snails (*Achatina fulica*) are a devastating pest in some parts of the world. They invade a field or a garden and devour seedlings, green vegetables, the bark and leaves of ornamental plants, and fruit rinds.

Ash on the soil is a deterrent, copper sulphate kills. Perhaps the simplest method of extermination them is as follows. Crush to powder two blocks of "Meta", the solid fuel briquettes used as quick fuel for camp cooking. It is metaldehyde. Mix the powder with 1 kg of rice (or wheat) husk or sawdust and sprinkle it along the edges of the field or garden bed in the evening. Next morning you will be delighted with a rich "harvest" of thousands of dead snails, which can profitably be mixed into your compost pile.

If the briquettes are not available locally, buy metaldehyde from a chemist of garden supply store and use 10 g of this per kilo of bait.

Instead of destroying the snails they can be collected alive. (Urchins once promised a pittance per hundred flies came back with tins full!) Liklik Buk says of snails "This pest is also useful for pig food (cooked), chicken food (cooked and dried), duck food (crushed and raw) and human food (cooked and spiced)." Cookery books give recipes for tasty snail dishes.

RECYCLING

Indians are great at improvisation, and adepts at recycling. Empty cans, broken wire, bits of glass, worn out plastic slippers, almost anything that one would throw away they salvage and turn into useful articles. They make something out of almost nothing! Here are just a few of their "creations".

Flour Strainer - They cut out the bottom of a round, shallow biscuit or sweet tin and replace it with a fine-mesh wire screen neatly soldered on.

Variable-Mesh Strainer - Alternatively to soldering the screen to the tin, it can be fixed to a narrow strip of tin round the circumference so that it just fits snugly into the bottom-less biscuit tin. Three such screens are provided to enable the user to do coarse, medium or fine straining. Obviously when making this strainer the bottom of the tin should not be cut to the very circumference, a 5 mm ledge should be left all around for the screen to rest on.

"Alladin" Chimney - The Alladin lamp is popular round the world, but some day the chimney is sure to break. Formerly a chimney cost Rs. 2.50; nowadays the price is Rs. 40.00! Fortunately a substitute has been found. You can easily make one as follows. Buy a globe for an ordinary kerosene lantern. These are of different sizes, so make sure the base has the same diameter as the Alladin chimney. Indian lantern globes, the taller ones, fit nicely. Next get a long narrow metal tin, some 20 cm long and 5 cm in diameter (the one shown once held rolls of Scotch tape).



Remove the top and bottom. This leaves a tube which makes the chimney proper. To one end of this attach a conical tin "skirt", top diameter to fit the tube, bottom to slip over the globe. Secure the skirt to the globe. This done, for a minimum of expense, you have a durable Allading chimney. This one lasted for fifteen years!

Pressure Lamp Globe - The Primus, Petromax, and other lanterns made in India have cylindrical globes. A cheap substitute, very commonly used, is made with 1 cm wide strips of waste glass pane (glaziers throw away plenty) held in place with a narrow tin channel top and bottom. The two channels are held together with three 5 mm strips of tin.

RAT DISPOSAL

The Mozambique Rat Trap: Mozambique is not cursed any more than most places round the world with superabundance of rats; but they seem to come in waves. Sometimes there are not so many around, and at other times they pop up all over the place. They attack the fields in droves and ruin the produce. But the men of Mozambique are smarter than the rats and have thought up an ingenious trap that catches them by the dozen.

In a field particularly subject to their deprivations a small pit is dug large enough to take a drum of any convenient size. The top of the drum is cut away, and the drum is placed in the pit so that its upper end is about 10 to 15 cm below ground level. Mud is packed round it, and the soil is made to slope from ground level to the drum. Water is poured in deep enough to prevent the rats from escaping by kicking the bottom of the drum and jumping out. A little chaff is sprinkled on the slope and a little on the surface of the water. The rats run about the slope inspecting the chaff in the hope of finding some grain, and then jump into the drum to examine the chaff there. They cannot get out again and end by drowning. Next morning a dozen or more drowned rats may be found in each drum.

A variation of the Mozambique method, that I read somewhere, stands an empty drum in the store room. A little grain that rats like is mixed with chaff and sprinkled on the bottom of the drum. A stick is left standing inside to give the rats a convenient way down. They are thus fed for two or three days, and when they are quite familiar with the set-up and know they can always find food in the drum, the stick is removed and the drum 3/4 filled with water. Plenty of chaff without any grain is sprinkled on the water to cover the entire surface. That night the rats will find no stick, but the height of the chaff is temptingly within reach; so they jump and get drowned.

Of the many poisons available, two that seem most suitable are Paris Green and barium carbonate (or barium chloride). These make the rat very thirsty, and he runs off to drink. It is only after drinking that he dies. The great advantage is thus achieved of his dying outside the house. Zinc phosphide is very good, but it acts much too fast. The rat sometimes dies before he can reach his hole; and if he dies under the flooring or above the ceiling, he stinks the house out and is hard to get at.

Of barium carbonate about 130 mg would kill a rat. Mix it with double its weight of bait. For a dog 6.5 mg are needed, though less might only make him sick.

The Bottle Trap: A method explained to me as one that works (though I have not tried it) uses an empty bottle. This is useful where there are many rats, as it disposes of several in a single night without need of re-setting. A bottle is fixed to a table, box or shelf, so that its neck sticks out. Below the neck is a deep container three-fourth full of water. The bottle neck is greased liberally with lard, cooking oil or other similar substance. In the cork is a nail or a short bit of wire holding some strong-smelling bait. The rat confidently runs along the bottle, but soon slips on the grease and falls into the water. And the trap is ready to welcome another rat. Make sure that the water is deep enough so that the rat cannot kick the bottom, reach the edge of the container and scramble out.

A variant to this is to hang the bait temptingly above the greased portion. Then, as the rat reaches up to get at it, he loses his balance and falls to his death.

THE NEPALI QUEEN EXCLUDER

Though villagers in Nepal have kept bees for centuries they have never gone in for beekeeping. Modern beekeeping seems to have crept into the country slyly only during the 1970's; and is still creeping. Beekeepers need queen excluders, and since none were available unless imported, an ingenious and enterprising individual set about making one. He succeeded so well that now he does a business marketing excluders.

Lacking zinc sheeting and the machinery to punch out slots accurately measured to $5/32$ of an inch, he bethought him of a substitute: bicycle spokes! He took thin aluminium strips, punched holes in the accurately spaced so as to leave a gap of 3.9 mm from one hole to the next. passed spokes through all the holes and fixed them in a wooden frame. He was lucky in that the spokes were just long enough to fit across the brood boxes of the Godavari Hive*, one of the popular hives used in Nepal. They are exactly the size of a British Standard Hive. They sell at Rs. 35/- each, which at the present rate of exchanges comes to approximately US \$ 2.50.

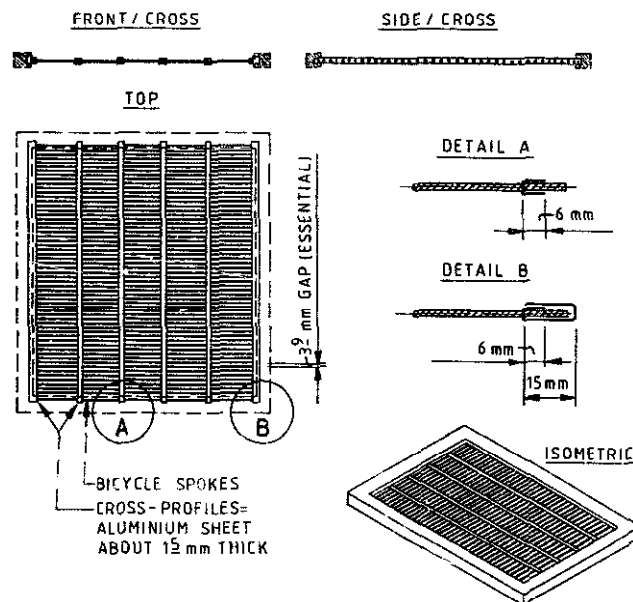

Those who have used them find them quite satisfactory. Laying queens cannot get through them. Occasionally it may happen that an unmated queen, whose abdomen is not swollen with eggs, does manage to slip through. But I believe this happens with foreign made zinc excluders too. Most probably it happens because the spacing of 3.9 mm ($5/32$ ") was calculated for the Italian queen, whereas the queen of the *apis cerana indica* is slightly smaller.

The diagram shows clearly how the excluder is made. Further explanations are hardly necessary.

* See description of this hive in the authors' booklet "Beekeeping"

FENCE POST DRIVER

Some time ago I visited a cattle development project for new settlers up the jungle zone of Villa Rica in Peru. One of the important first steps for newly established farmers is to fence in their new pastures.

The fence posts are made out of locally cut wood, either round posts up to a diameter of twenty centimetres, or out of wedge-shaped pieces of hardwood produced from split logs. The latter are preferable because they resist rotting longer than the softer less durable round posts.

The land is often very hilly and the fences have to be installed on very steep slopes. The local methods of installing the posts is either to dig a hole with a crowbar and shovel, or to drive them in with a wooden mallet. On steep hills and rugged terrain the latter might be quite awkward, requiring a stepladder or a sawhorse to reach the necessary height to drive the posts in.

Faced with this problem I introduced a system that used to be utilized in Switzerland years ago. It works as follows:

- Take a discarded piece of cast-iron or seam-welded (or any kind of) steel pipe about 80-100 cm long with a diameter of between 18-28 centimetres, weld it shut with a steel plate on one end, on each side of the pipe weld on handlebars out of used pipe of any dimension to hold comfortably. For additional strength a cross-piece across the middle of the welded-in top steel plate to join the handlebars is advisable.
- To drive in the posts simply position them on the indicated spot, slip the driver over the top - one man holding on to the handlebar, on each side - and start whacking it up and down till the post has reached the desired level. No digging, no wobby ladder, no split mallets. It is easier, faster and uses the combined driving force of two men. At a pinch one man could use the tool.

Materials for making this tool may be easily available.

(G. Baumann, Switzerland / Source: AT of ITDG)

FENCE POST DRIVER

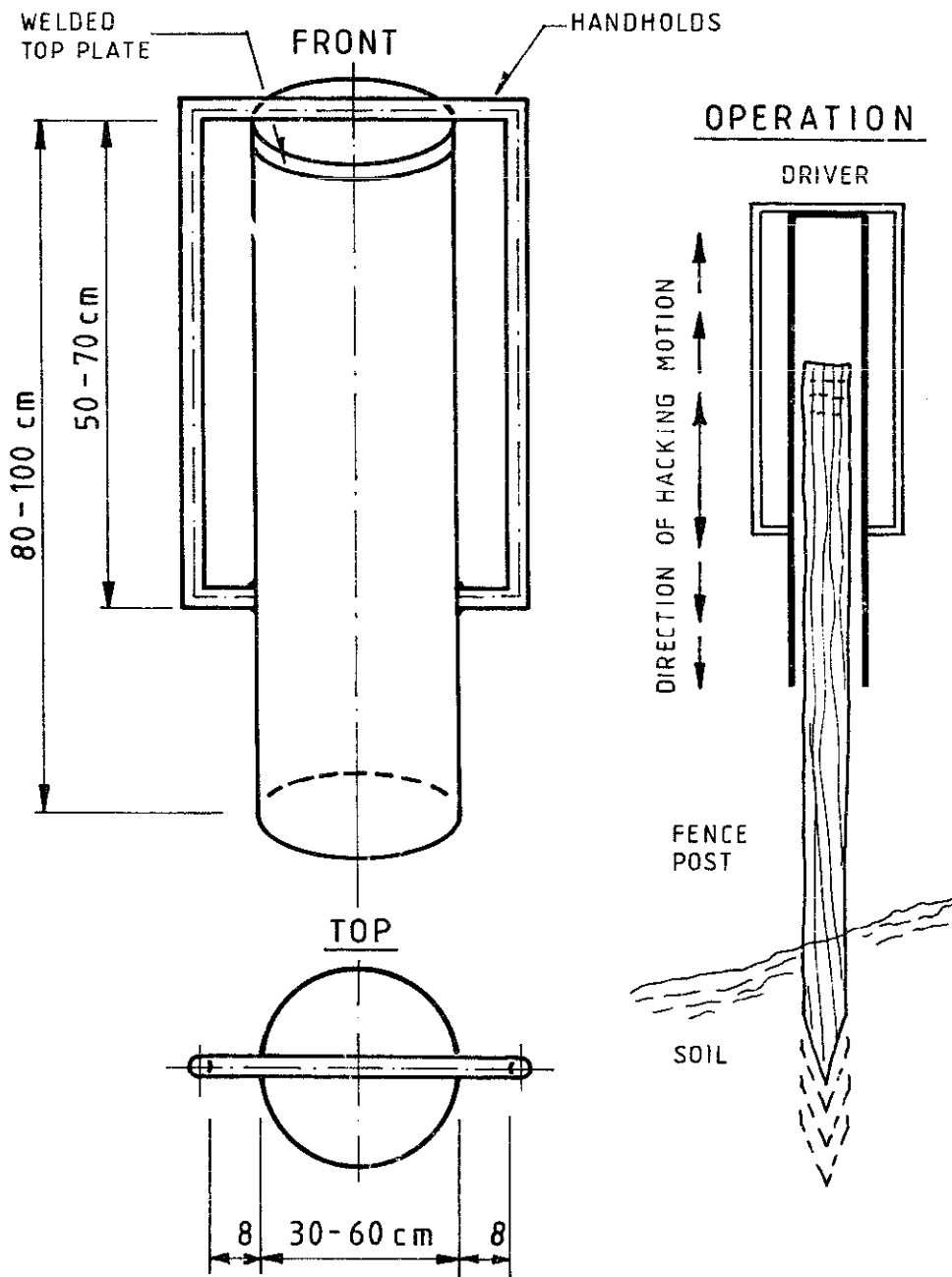

ACKNOWLEDGEMENT

It is some five years since the first volume of Mini Technology was published. With the steady encouragement of our publisher, Mr. R.K. Sharma, this new edition has become a reality. It is he who keeps us working and because of him we are able to present this kind of booklet. It is certain that nobody will become rich from this printing; hence it is for truly other values than the monetary ones that these works are being done. We are very thankful to Mr. R.K. Sharma of Sahayogi Press for his initiatives and steady encouragements.

The authors

M I N I T E C H N O L O G Y

VOLUME II

by

A. Bachmann and B.R. Saubolle

This second volume continues the information on technology for rural areas and developing countries, where electricity is not yet available from the power grid. It gives suggestions based on experience on fuel efficient stoves, smokeless kitchens, energy from water; explains also methods of rat disposal, etc.

A welcome addition to the literature in this field!



COMPLIMENTS OF UNICEF

Printed in Nepal
at Sahayogi Press